

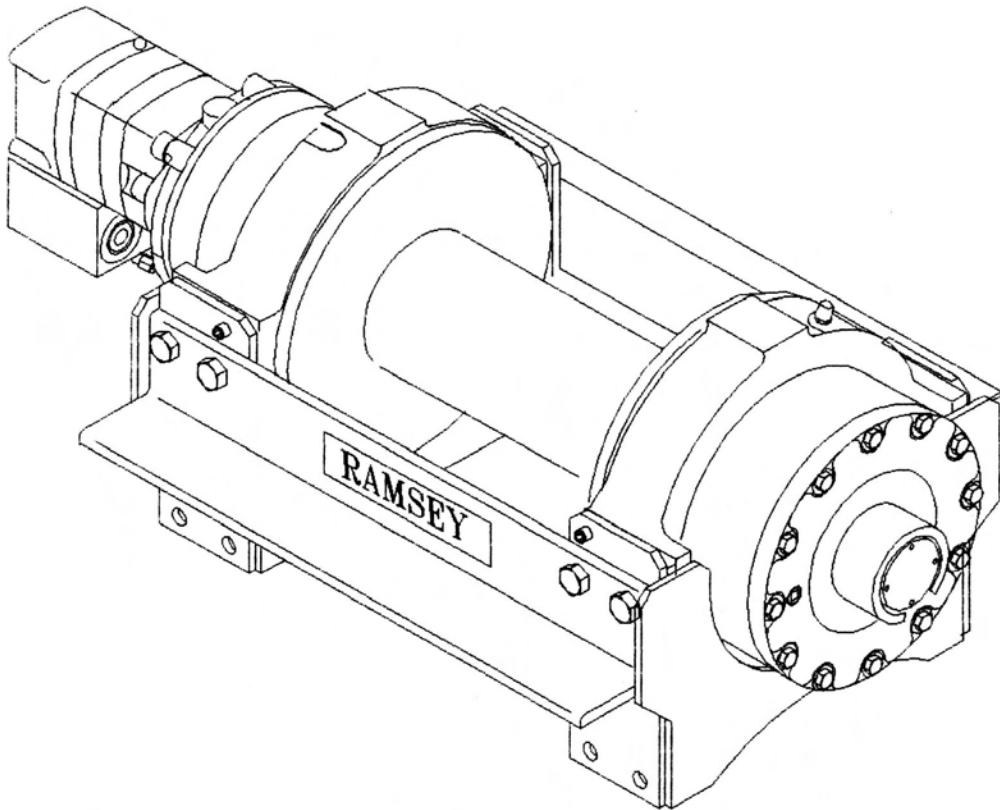

# OPERATING, SERVICE AND MAINTENANCE MANUAL



## MODEL RPH-30,000 INDUSTRIAL PLANETARY WINCH



**CAUTION:** READ AND UNDERSTAND THIS MANUAL BEFORE INSTALLATION AND OPERATION OF WINCH. SEE WARNINGS!

## TABLE OF CONTENTS

INTRODUCTION.....	1
WARRANTY INFORMATION.....	1
SPECIFICATIONS.....	1
WARNINGS.....	1
WINCH FRAME MOUNTING.....	2
CABLE INSTALLATION.....	2
HYDRAULIC SYSTEM REQUIREMENTS.....	2
PERFORMANCE CHARTS.....	3
CLUTCH OPERATION.....	3
WINCH OPERATION.....	3
MAINTENANCE.....	4
TROUBLE SHOOTING GUIDE.....	4
INSTRUCTIONS FOR OVERHAUL.....	5-12
MOUNTING CONFIGURATIONS.....	12
DIMENSIONAL DRAWING.....	13
PARTS LIST AND PART DRAWING.....	14-15
LIMITED WARRANTY.....	16

# RAMSEY HYDRAULIC PLANETARY WINCH MODEL RPH 30,000

## PLEASE READ THIS MANUAL CAREFULLY

This manual contains useful ideas in obtaining the most efficient operation from your Ramsey Winch, and safety procedures one needs to know before operating a Ramsey Winch. Do not operate this winch until you have carefully read and understand the "WARNINGS" and "OPERATION" sections of this manual.

## WARRANTY INFORMATION

Ramsey Winches are designed and built to exacting specifications. Great care and skill go into every winch we make. If the need should arise, warranty procedure is outlined on the back of your self-addressed postage paid warranty card. Please read and fill out the enclosed warranty card and send it to Ramsey Winch Company. If you have any problems with our winch, please follow instructions for prompt service on all warranty claims. Refer to back page for limited warranty.

## SPECIFICATIONS\*

Rated Line Pull (lbs.).....		30,000					
(Kgs.).....		13,605					
Gear Reduction.....		31.89:1					
Weight (without cable).....		486 lb. (220 Kgs.)					
LAYER OF CABLE		1	2	3	4	5	6**
*Rated line pull per layer	Lbs. Kg.	30,000 13,605	25,200 11,430	21,700 9,840	19,100 8,660	17,000 7,700	15,400 6,980
*Cable capacity	Ft. M.	30 9	75 22	120 36	175 53	235 71	300 91
*Line speed (at 15 GPM)	FPM MPM	19 5.7	23 7.0	26 7.9	29 8.8	33 10.0	36 10.9
* These specifications are based on recommended wire rope of .62 inch dia. extra improved plow steel or equivalent							
** Last layer does not conform to SAE J706							

NOTE: The rated line pulls shown are for the winch only. Consult the wire rope manufacturer for wire rope ratings.

## WARNINGS:

CLUTCH MUST BE TOTALLY ENGAGED BEFORE STARTING THE WINCHING OPERATION.

DO NOT START WINCH MOTOR BEFORE ENGAGING CLUTCH

DO NOT DISENGAGE CLUTCH UNDER LOAD.

STAY OUT FROM UNDER AND AWAY FROM RAISED LOADS.

STAND CLEAR OF CABLE WHILE PULLING. DO NOT TRY TO GUIDE CABLE.

DO NOT EXCEED MAXIMUM LINE PULL RATINGS SHOWN IN TABLE.

DO NOT USE WINCH TO LIFT, SUPPORT, OR OTHERWISE TRANSPORT PEOPLE.

A MINIMUM OF 5 WRAPS OF CABLE AROUND THE DRUM BARREL IS NECESSARY TO HOLD THE LOAD.

CABLE ANCHOR IS NOT DESIGNED TO HOLD LOAD.

## WINCH FRAME MOUNTING

Use (8) 5/8 inch diameter grade 5 or better bolts to attach mounting frame to wrecker.

## CABLE INSTALLATION

1. Unwind cable by rolling it out along the ground to prevent kinking. Securely wrap end of wire rope, opposite hook, with plastic or similar tape to prevent fraying.
2. Insert the end of cable, opposite hook end, into the hole in drum barrel. Secure cable to drum barrel using setscrew furnished with winch. **TIGHTEN SCREW SECURELY.**
3. Carefully run the winch in the "reel-in" direction. Keeping the tension on the end of cable, spool all the cable onto the cable drum, taking care to form neatly wrapped layers.

## HYDRAULIC SYSTEM REQUIREMENTS

Refer to the performance charts below to properly match your hydraulic system to RPH 30000 winch performance. The charts consist of:

(1) Line pull (lbs.) first layer, vs. working pressure (PSI) and (2) Line speed, first layer (FPM) vs. gallons per minute (GPM). Performance based on a motor displacement of 9.6 cubic inches with 15 GPM maximum flow rate. See page 13 for motor port size.

## TYPICAL LAYOUT

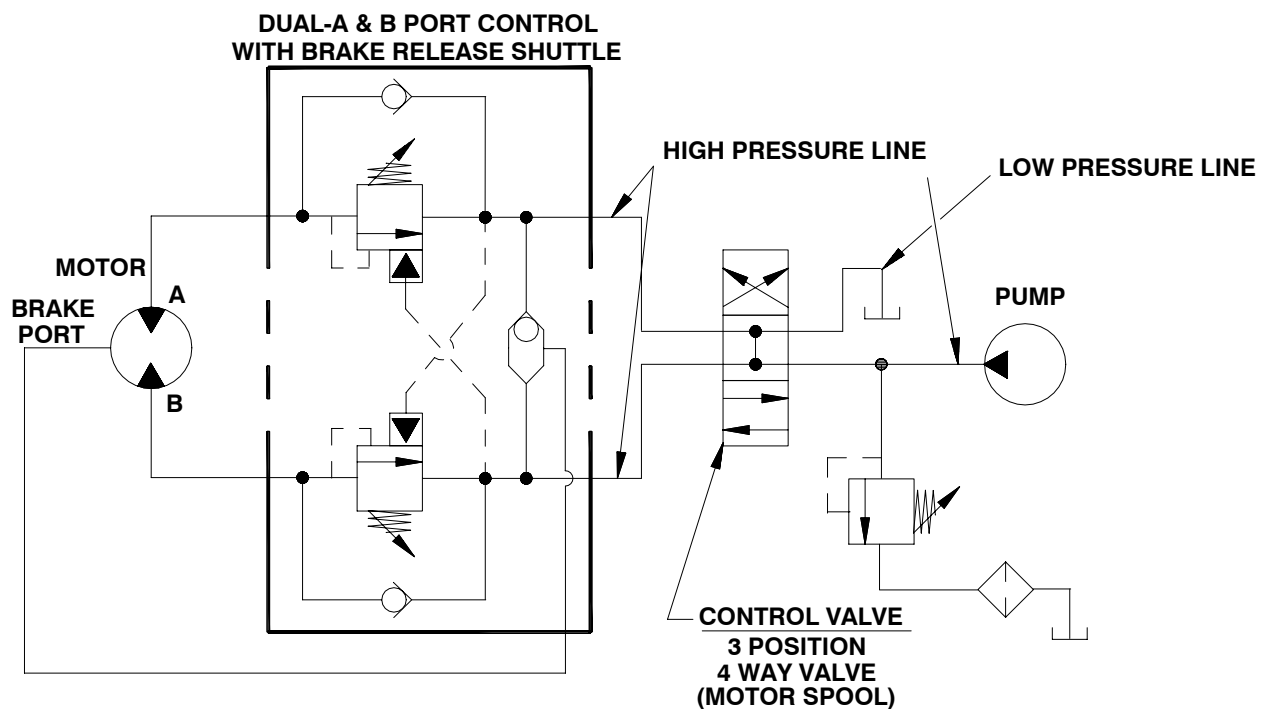

## PERFORMANCE CHARTS

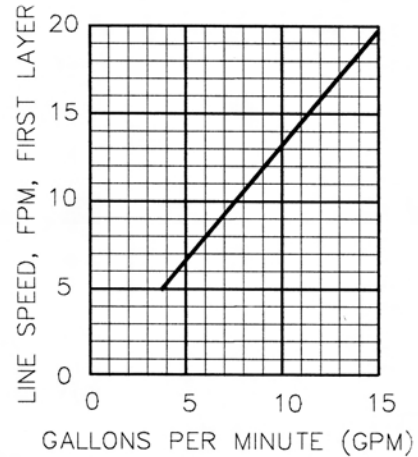
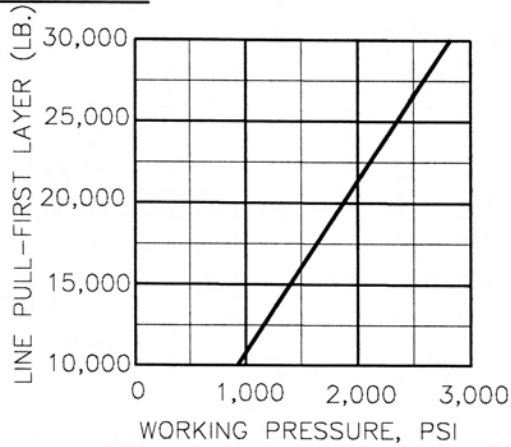

BASED ON 9.6 CU. IN./REV. MOTOR

## CLUTCH OPERATION

### To engage clutch:

1. Move the clutch control valve to the "clutch-engaged" position.
2. Anytime the temperature is below freezing, run motor in the "cable out" direction only until the drum starts to turn.
  - 2a. In extreme cold temperatures (below 0° F/-18° C), pull out on the cable by hand only until the drum starts to turn.
3. Wait at least 3 seconds for the clutch to fully engage, after which the winch is ready to winch in the cable.

**WARNING:** Do not attempt to engage the clutch by first running the winch motor and then moving the clutch control valve to the "clutch-engaged" position while the motor is running. Do not start picking up the load at the same time the clutch is being engaged.

### To disengage clutch:

1. Run the winch in the "cable out" direction until the load is off the cable.
2. Move the clutch control valve to the "clutch-disengaged" position.
3. The cable may now be pulled off by hand

## WINCH OPERATION

The best way to get acquainted with how your winch operates is to make test runs before you actually use it. Plan your test in advance. Remember, you hear your winch, as well as see it operate. Get to recognize the sounds of a light steady pull, a heavy pull, and sounds caused by load jerking or shifting. Gain confidence in operating your winch and its use will become second nature with you.

The uneven spooling of cable, while pulling a load, is not a problem, unless there is a cable pileup on one end of drum. If this happens reverse the winch to relieve the load and move your anchor point further to the center of the vehicle. After the job is done you can unspool and rewind for a neat lay of the cable.

## MAINTENANCE

Adhering to the following maintenance schedule will keep your winch in top condition and performing as it should with a minimum of repair.

### A. WEEKLY

1. Check the oil level and maintain it to the oil level plug. If oil is leaking out, determine location and repair.
2. Check the pressure relief plug in top of the gear housing. Be sure that it is not plugged.
3. Lubricate cable with light oil.

### B. MONTHLY

1. Check the winch mounting bolts. If any are missing, replace them and securely tighten any that are loose. Use grade 5 or better bolts.
2. Inspect the cable. If the cable has become frayed with broken strands, replace immediately.

### C. ANNUALLY

1. Drain the oil from the winch annually or more often if winch is used frequently.
2. Fill the winch to the oil level plug with clean kerosene. Run the winch a few seconds with no load in the reel in direction. Drain the kerosene from the winch.
3. Refill the winch to the oil level plug with all purpose SAE 80W-140 gear oil.
4. Inspect frame and surrounding structure for cracks or deformation.

## TROUBLE SHOOTING GUIDE

<u>CONDITIONS</u>	<u>POSSIBLE CAUSE</u>	<u>CORRECTION</u>
OIL LEAKS FROM WINCH	1. Seals damaged or worn. 2. Too much oil. 3. Damaged gasket.	1. Replace seal. 2. Drain excess oil. Refer to OPERATION. 3. Replace gasket.
WINCH RUNS TOO SLOW	1. Low flow rate 2. Hydraulic motor worn out.	1. Check flow rate. Refer to HYDRAULIC SYSTEMS flow chart page 3. 2. Replace motor.
CABLE DRUM WILL NOT FREESPOOL	1. Clutch not disengaged	1. Check air pressure to clutch cylinder 90 PSI minimum required-Refer to page 13.
BRAKE WILL NOT RELEASE	1. Air in hydraulic system	1. Bleed air from brake. Refer to page 12.

## INSTRUCTIONS FOR OVERHAUL

1. Drain oil from gear housing (item #10) by removing plug (item #43) from end bearing. Remove reducer and relief fitting (items #42 & #37).

If new air cylinder is required, remove air cylinder (item #32) from adapter (item #4) by removing (4) capscrews (item #23). Remove washer (item #26), nut and setscrew (items #27 & #22) and insert (item #29) from end of air cylinder rod. Apply Loc-tite to threads of nut (item #29) and thread onto setscrew (item #22) to 3/8 inch from drive end, as shown below. Apply Loc-tite to threads of setscrew and thread insert (item #29) over end of setscrew and against nut. Use setscrew and nut to thread insert (item #29) into end of air cylinder rod. Tighten nut against cylinder rod, keeping 3/8 inch distance from drive end of setscrew to nut. If breather vent (item #38) is damaged, remove and replace. Remove air cylinder adapter (item #4) and gasket (item #36) from gear housing cover by unscrewing (4) capscrews (item #18).

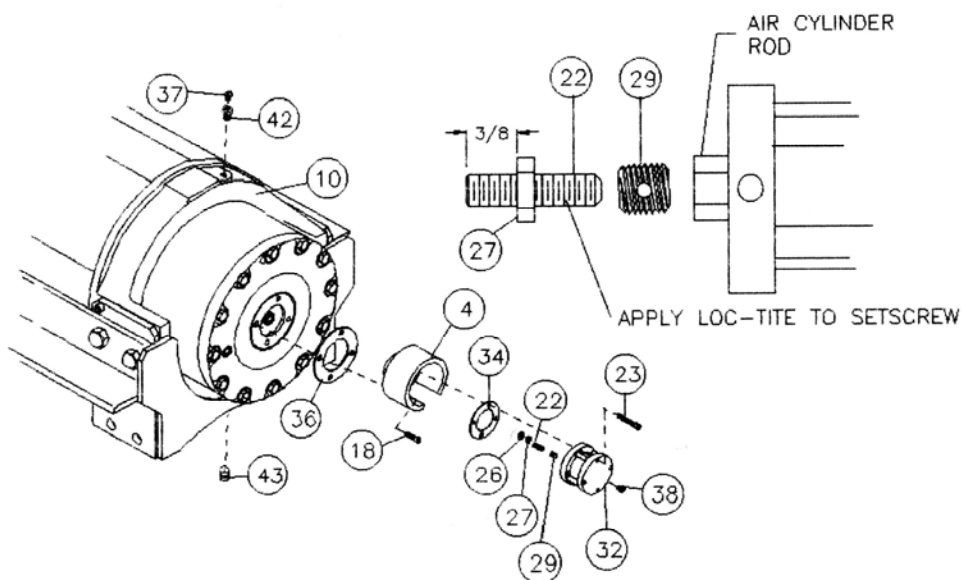

2. Disconnect tube (item #46) from elbow (item #30) and fitting (item #31) on bottom of brake (item #33). Remove motor (item #39) and gasket (item #33b) by removing (2) capscrews (item #21). Remove valve (item #47), if needed, from motor by loosening (3) capscrews (item #19)

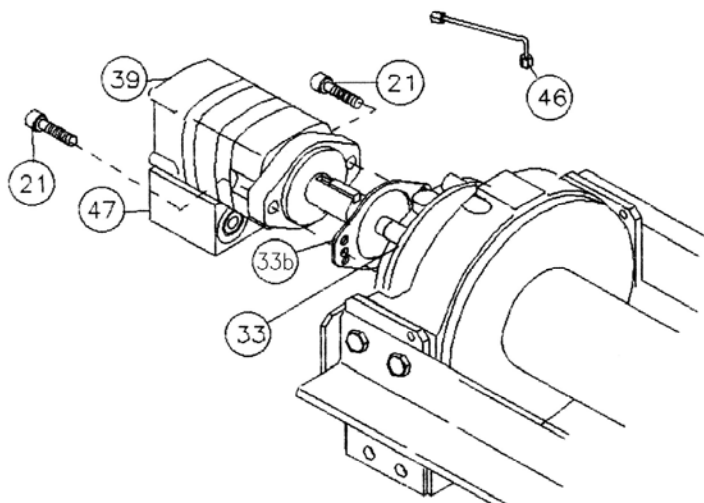

3. Remove brake assembly screws (item #48) from brake (item #33a) to access mounting screws (item #20) attaching brake adapter plate (item #33d) to end bearing (item #9). Caution: Brake is spring loaded by clutch spring and must be restrained against end bearing as mounting screws are removed. Remove coupling (item #7) and gasket (item #33e) from the end bearing. Take note of the mounting configuration for proper mounting of parts during re-assembly.

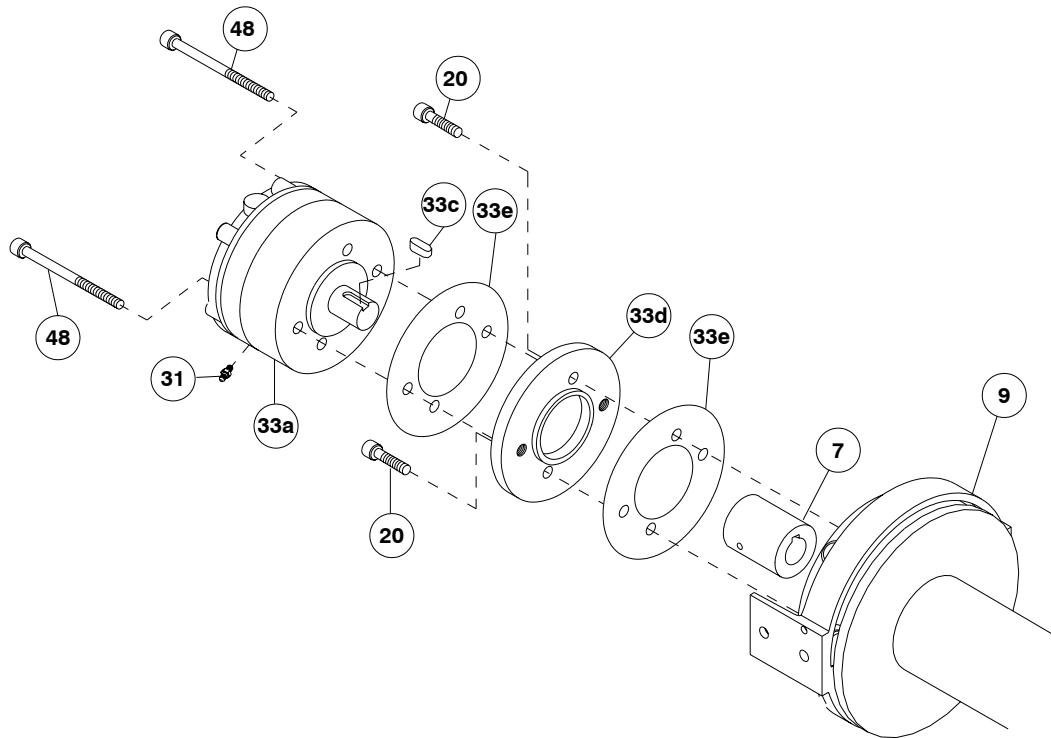

4. Remove winch from upright mounting frame (item #2) by removing (8) capscrews (item #17), (8) lockwashers (item #24) and (4) shoulder bolts (item #28). Pull motor end bearing (item #9) from drum assembly (item #1).

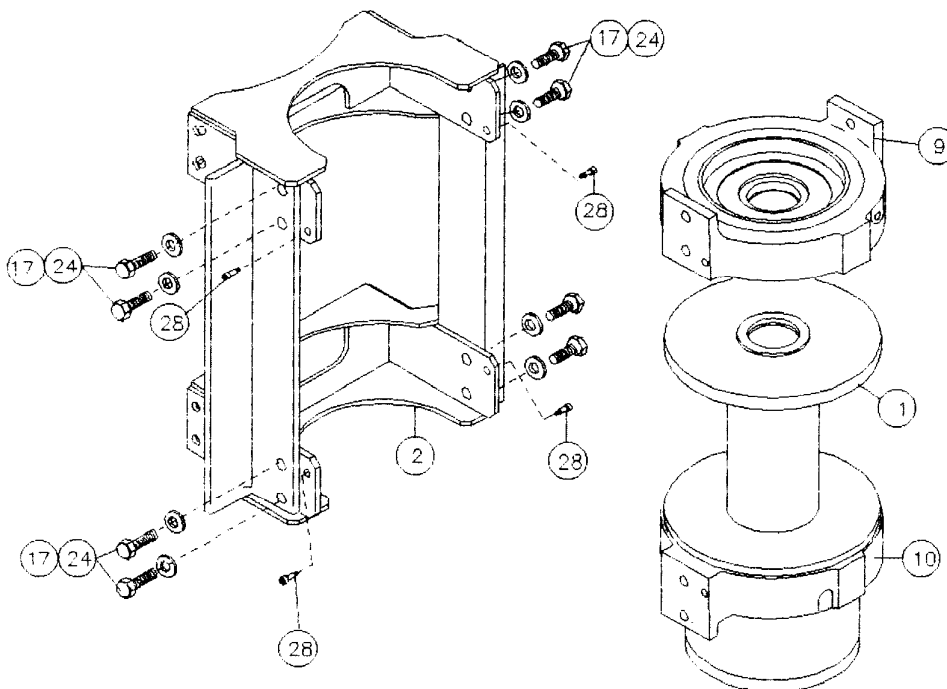



5. Pull drum assembly (item #1) upward from end bearing (item #10). Remove quad-rings (item #40 & #41) from grooves in drum bushings. Remove input shaft (item #12), clutch spring (item #45) and washer (item #25) from end bearing (item #10). Examine key (item #11) and input shaft for signs of wear, replace if damaged.

Examine drum assembly (item #1) for signs of wear. If splines inside of drum driver (332162) are damaged, drum driver must be replaced. Remove drum driver by unscrewing (8) capscrews (414964). Place well oiled o-ring (462053) into drum driver groove and attach driver to drum (332161) using (8) capscrews (414964). Torque capscrews to 120 ft. lbs. each, in criss-cross pattern.

Press old bushings from drum and drum driver. Remove o-rings (462054 & 462052) from grooves in drum and drum driver bushing (412088). Place well oiled o-rings (462054 & 462052) into grooves in drum and outer diameter of drum driver bushing (412088). Press new bushing (412087) into end of drum opposite drum driver and press bushing (412088) into drum driver until flange of bushings are flush against drum and driver.

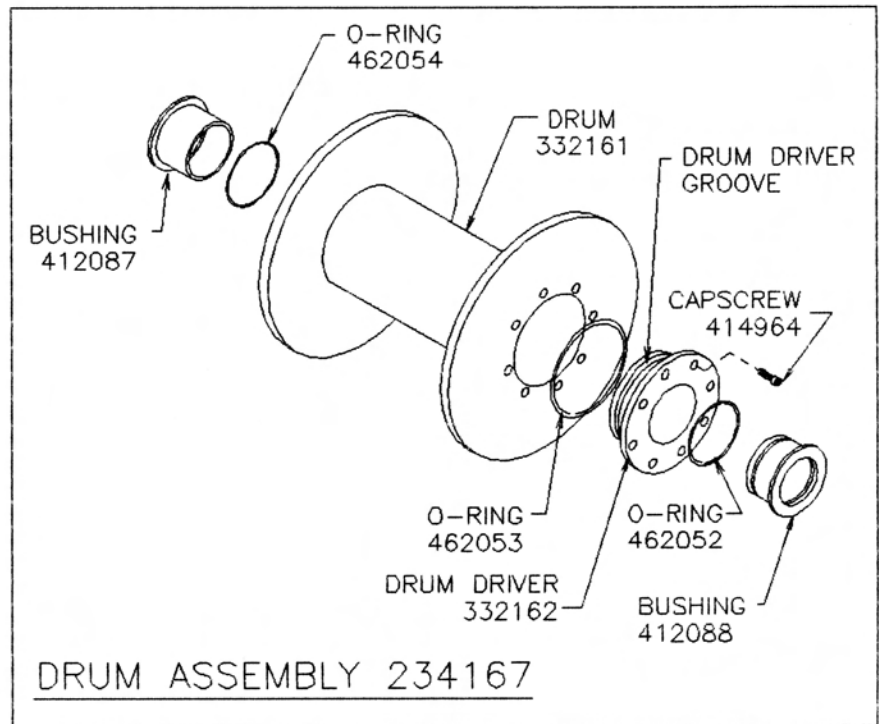
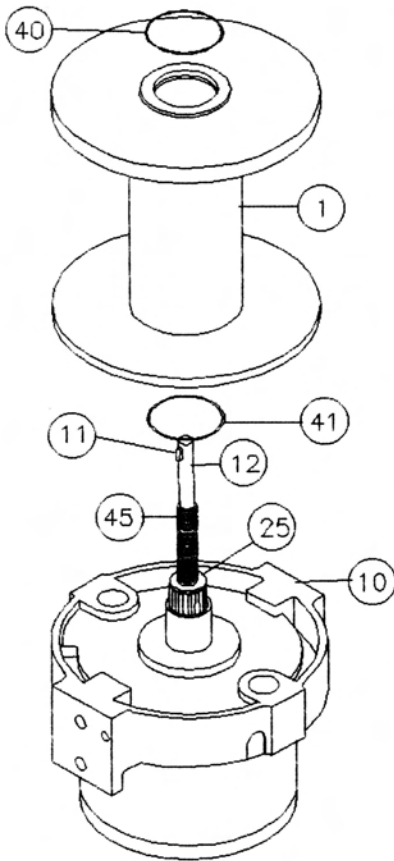

6. Remove output coupling (item #8) and coupling shaft (item #6) from end bearing (item #10). Examine bearings (item #14), pressed in output coupling (item #8), for signs of wear. Replace bearings, if necessary, by pressing old bearings from coupling and press new bearings (item #14) into each end of output coupling (item #8). Place coupling shaft (item #6) into bearings (item #14).

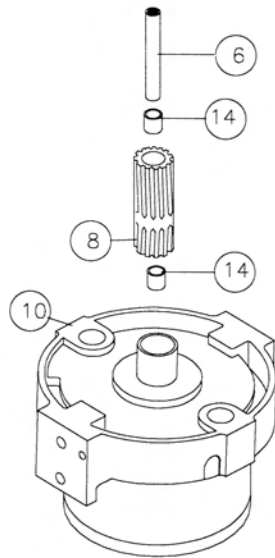

7. Remove (12) capscrews (item #16) to pull gear housing cover from ring gear. Remove input thrust washer, sun gear and carrier assemblies from inside of ring gear. Remove ring gear from end bearing (item #10). Examine shifter shaft (item #13) for signs of wear, replace if necessary. Examine bushing (item #15) for signs of wear. Replace bushing, if necessary, by pressing old bushing from housing and pressing new bushing into place.

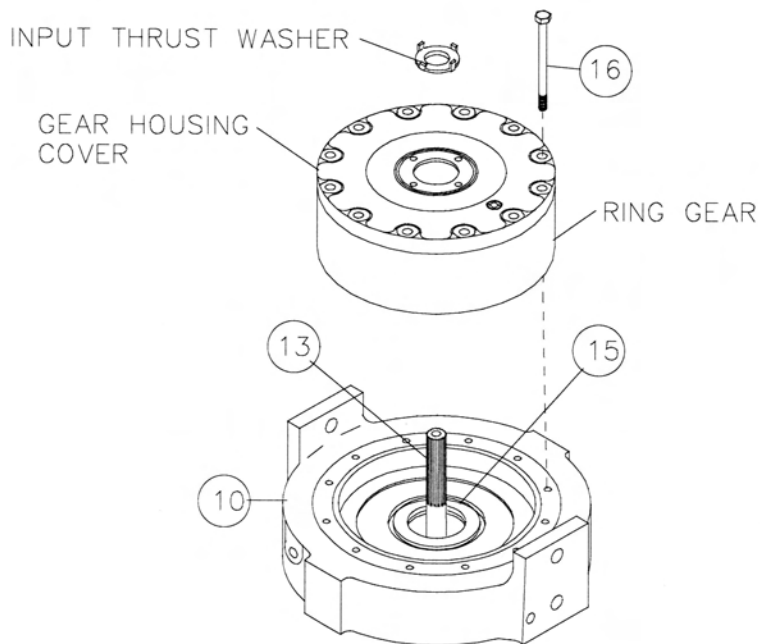

8. NOTE: DETERMINE MOUNTING CONFIGURATION OF WINCH (R.H. or L.H. MOUNTED) BEFORE ATTACHING UPRIGHT FRAME TO WINCH, TO ASSURE PARTS ARE MOUNTED TO PROPER SIDE, REFER TO WINCH MOUNTING CONFIGURATIONS, STEP 14 PAGE 12.

Seat well oiled quad-rings (item #40 & #41) into groove of bushing in each end of drum assembly (item #1), as shown. Carefully set drum assembly (item #1) down over motor end bearing (item #9). Lift gear housing end bearing (item #10) and set into place on drum assembly. Attach upright frame (item #2) to end bearings. Install (4) shoulder bolts (item #28) and hand tighten. Install (8) capscrews with lockwashers (item #17 & #24). Tighten (4) inner-most capscrews securely, check rotation of cable drum. Tighten (4) outer-most capscrews securely, check rotation of cable drum. Torque capscrews, in above inner-most then outer-most pattern, to 250 ft. lbs. each. Torque (4) shoulder bolts to 30 ft. lbs. each. Make sure cable drum assembly rotates freely at this point.

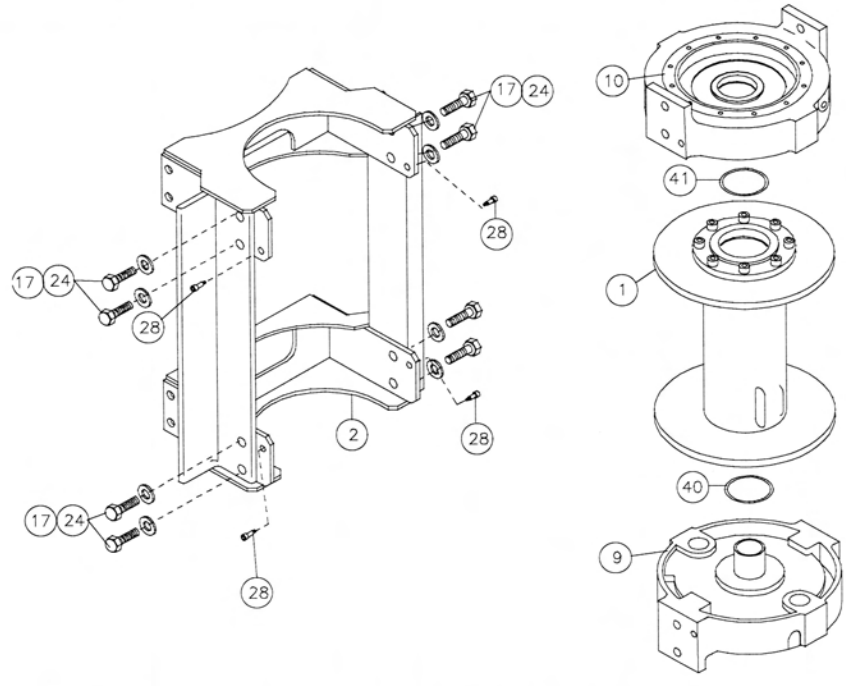

9. Gently tap key (item #11) into keyway of input shaft (item #12). Liberally apply grease to shoulder of input shaft (item #12). Place spring (item #45) over splined end of shaft. Use grease to hold spring in place on shaft. Place spring and splined end of shaft through motor end bearing (item #9) and drum until shaft extends through bushing (item #15). Place clutch washer (item #25) over splined end of shaft and against spring.

Place end of output coupling assembly (item #8), with longest splines, through end bearing bushing (item #15) and mesh shaft coupling spline with splined end of shaft. Place short splined end of shifter shaft (item #13) through washer (item #25) and into shaft coupling (item #6), meshing splines of shifter shaft with splines in shaft coupling.

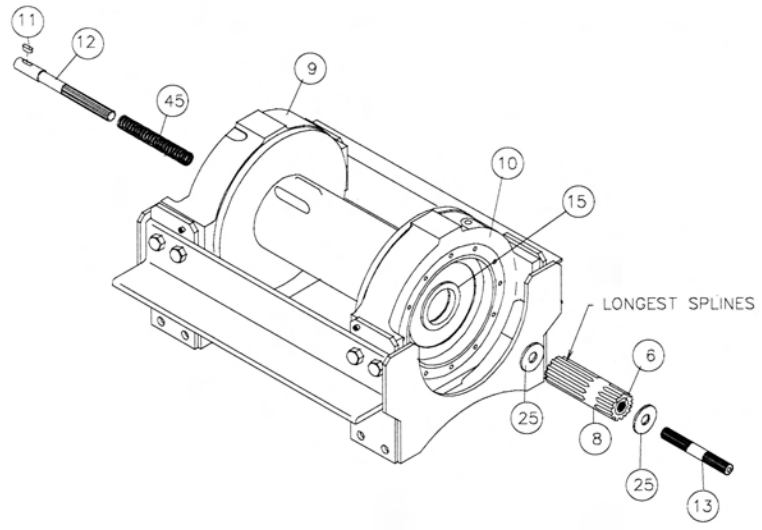

10. Apply RTV sealing compound to ring gear mounting surface of end bearing (item #10). Place ring gear onto end bearing, aligning holes in ring gear with holes and gear housing end bearing. Use (2) capscrews to temporarily secure ring gear to end bearing.

Place (2) gear carrier assemblies into ring gear meshing carrier gears with ring gear. Remove (2) temporary capscrews, making sure that ring gear and carrier assemblies are securely against end bearing (item #10). Apply RTV sealing compound to cover mounting surface of ring gear (item #3) and attach cover to ring gear. Use (12) capscrews (item #16) to secure gear box to gear housing end bearing. Torque capscrews to 39 ft. lbs. each, in criss-cross pattern.

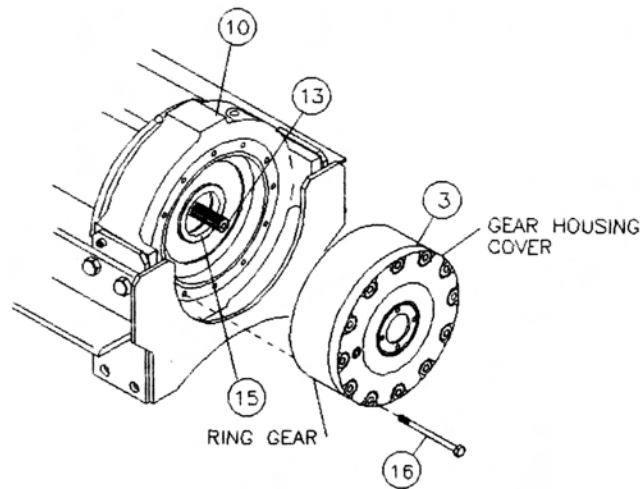

11. Slide input sun gear over shifter shaft (item #13) and mesh with teeth of input carrier. Apply grease to input thrust washer and place into slots of air cylinder adapter (item #4). Place gasket (item #36) into position on gear box cover with sealer and attach adapter to cover using (4) capscrews (item #18). Apply Loctite PST thread sealer to threads of capscrews. Torque capscrews to 13 ft. lbs. each, in criss-cross pattern.

Pull rod from air cylinder as far as possible. Slide washer (item #26) over setscrew (item #22) and against nut attached to air cylinder rod. Place setscrew into hole of shifter shaft (item #13). Attach new air cylinder (item #32) and gasket (item #34) with sealer, to adapter using (4) capscrews (item #23). Apply Loctite PST thread sealer to threads of capscrews. Torque capscrews to 5 ft. lbs. each, in criss-cross pattern.

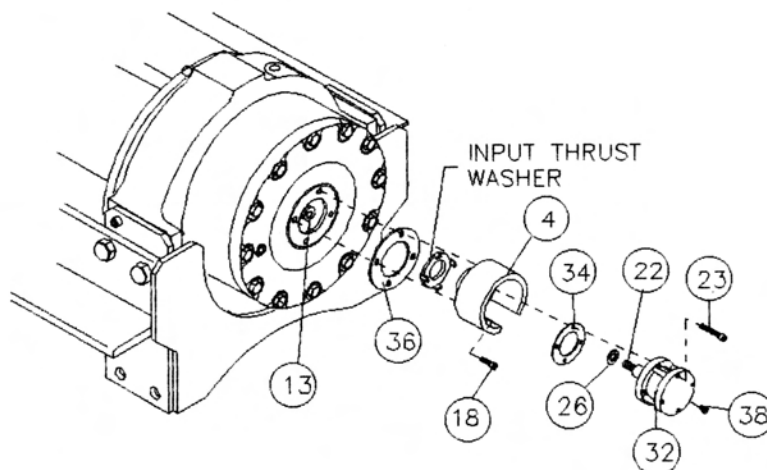

12. Align key way of coupling with key on end of input shaft inside end bearing assembly. Slide coupling over end of shaft. Place gasket (item #33e) into position on motor mounting surface of end bearing (item #9). Use (2) screws (item #20) to attach adapter plate (item #33d) to motor end bearing. Torque capscrews to 85 ft-lbs. each. Place second gasket (item #33e) on adapter plate. Insert brake shaft with key (item #33c) into coupling. Re-attach brake (item #33a) to adapter plate using brake assembly screws (item #48). Torque capscrews to 97 ft-lbs. each.

**Note:** Care must be taken to assure brake assembly and adapter plate are seated properly prior to installing assembly bolts (item #48). Damage will occur to rotor stack or shaft snap ring if not properly installed.

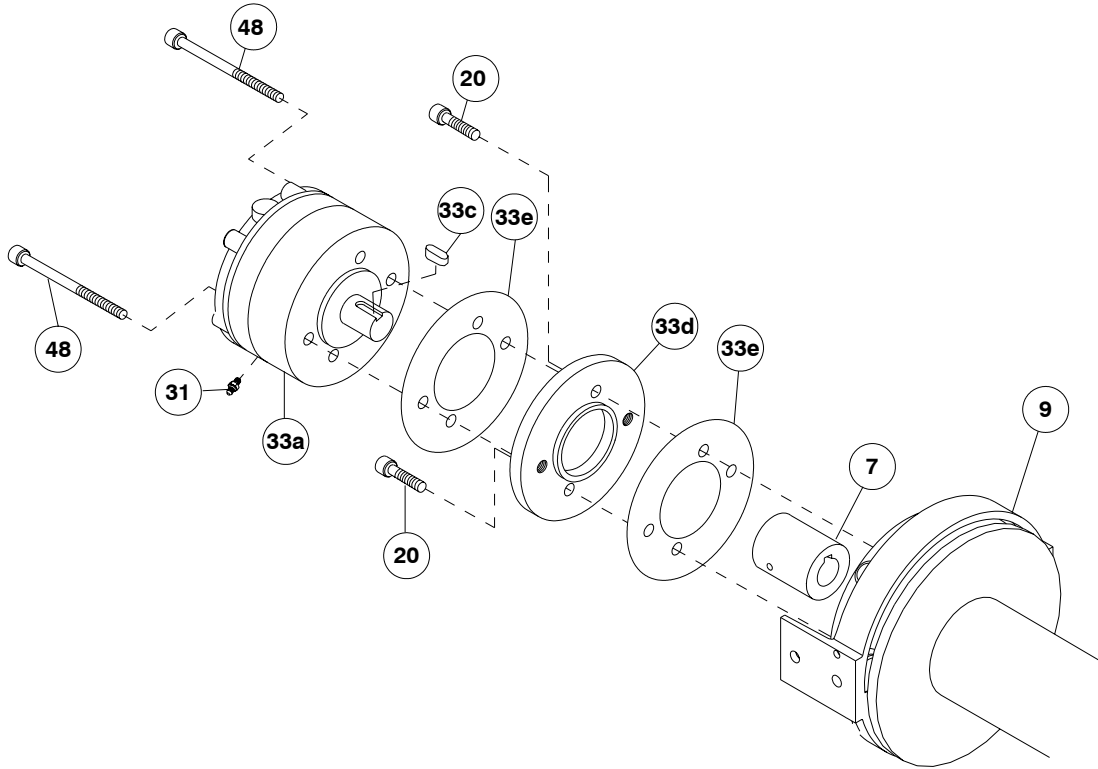

13. Attach motor (item #39) with gasket (item #33b) to brake (item #33). Use (2) capscrews (item #21) and torque to 74 ft. lbs. each. Securely connect tube (item #46) to elbow (item #30) in bottom of valve and fitting (item #31) in bottom of brake (item #33).

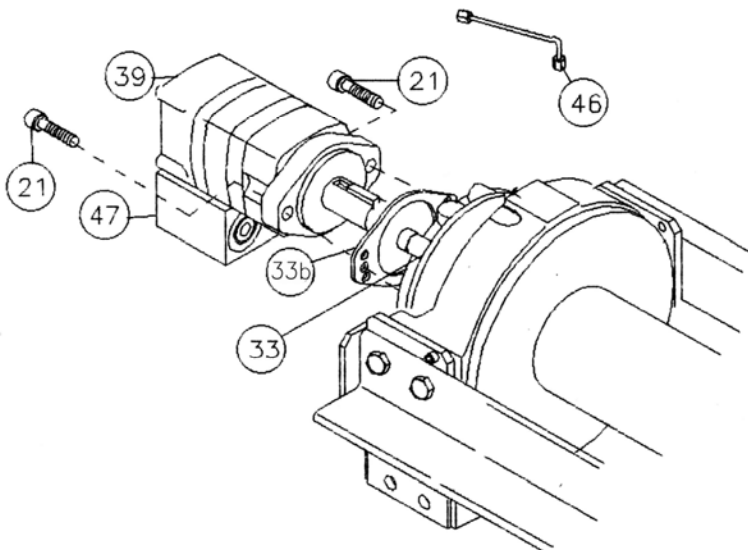

14. Apply Permatex to threads of plug (item #43). Thread plug into tapped hole in bottom of gear housing end bearing (item #10). Pour approx. 2.50 pints of SAE 80W-140 oil into end bearing. Check oil level by removing oil plug noted below. Insert relief fitting (item #37) and thread reducer (item #42) into end bearing at oil fill hole. Be sure breather vent (item #38) and relief fitting (item #37) are not damaged and in good operating condition. Replace if necessary.

Install winch and connect pressure lines. Bleed pressure release section of brake by loosening bleeder fitting on brake and allowing air to escape while slowly applying hydraulic system pressure to the winch (refer to bleeder fitting in step 13). Apply at least 230 PSI pressure to release brake and verify that brake releases, by observing that the winch drum rotates

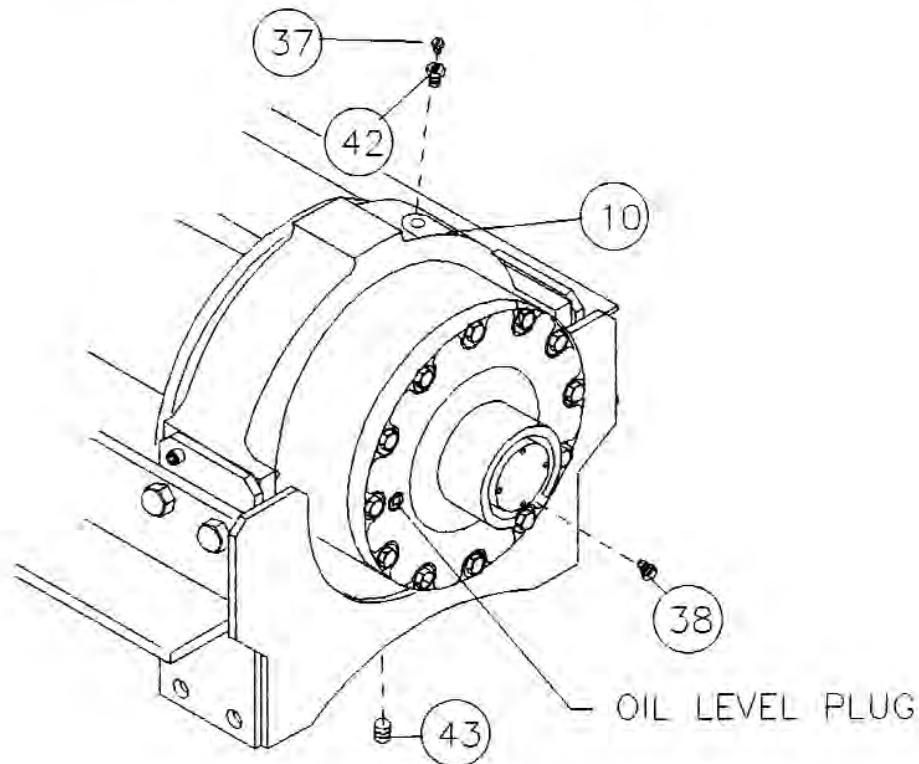

15. Check proper operation of clutch by applying air pressure to clutch air cylinder to disengage clutch. Verify that winch freespool. Re-engage clutch. A loud noise should be heard when clutch engages. Winch drum should not freespool.
16. Operate winch forward and reverse to verify that drum rotates.

# WINCH MOUNTING CONFIGURATIONS

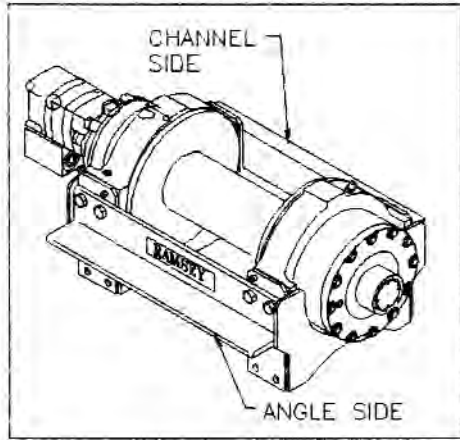

R. H. MOUNTING  
CONFIGURATION

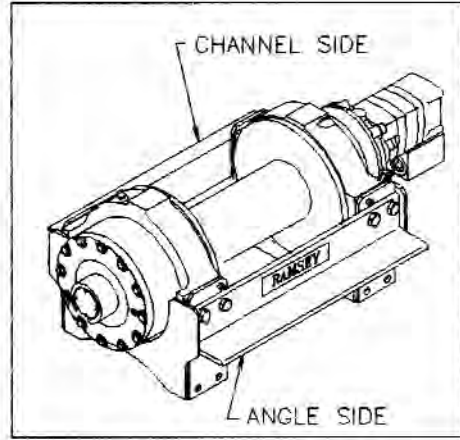

L. H. MOUNTING  
CONFIGURATION

## NOTES



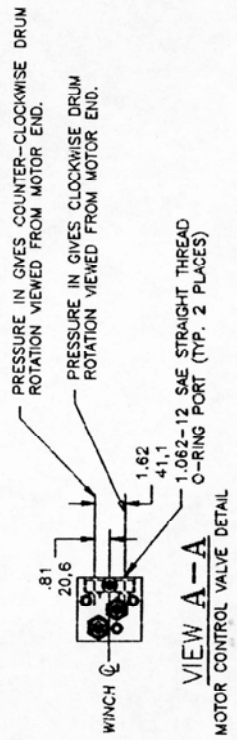
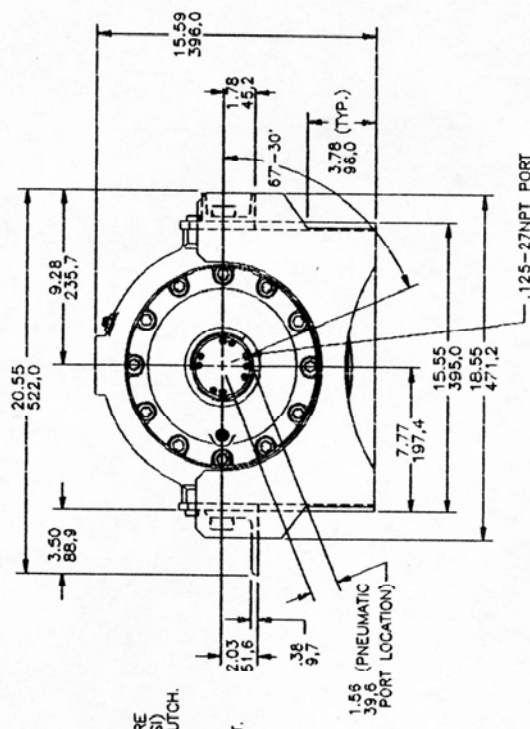
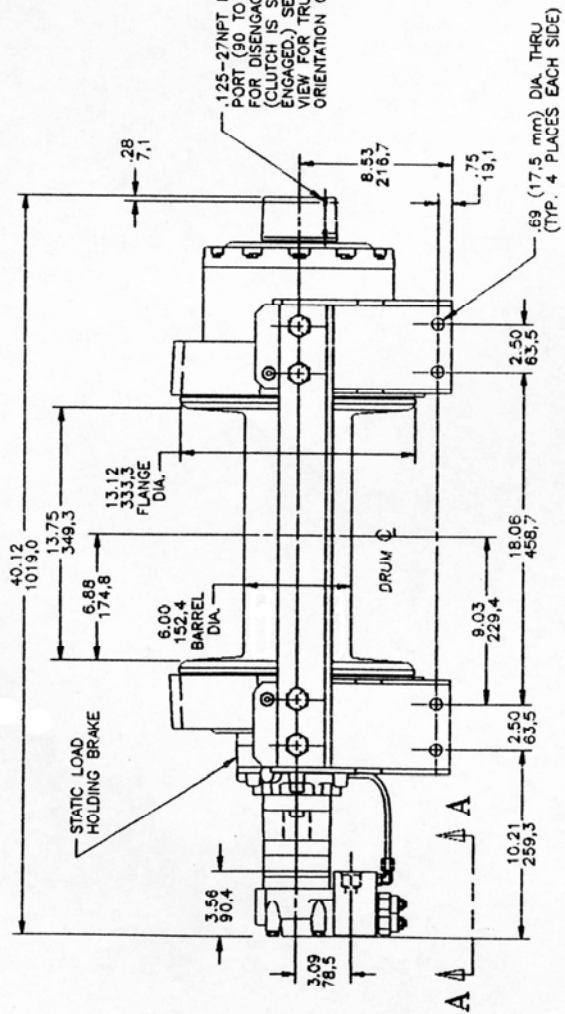

PRESSURE IN GIVES COUNTER-CLOCKWISE DRUM ROTATION VIEWED FROM MOTOR END.  
 PRESSURE IN GIVES CLOCKWISE DRUM ROTATION VIEWED FROM MOTOR END.

DIMENSIONS SHOWN ARE INCHES OVER MILLIMETERS

# MODEL RPH 30,000

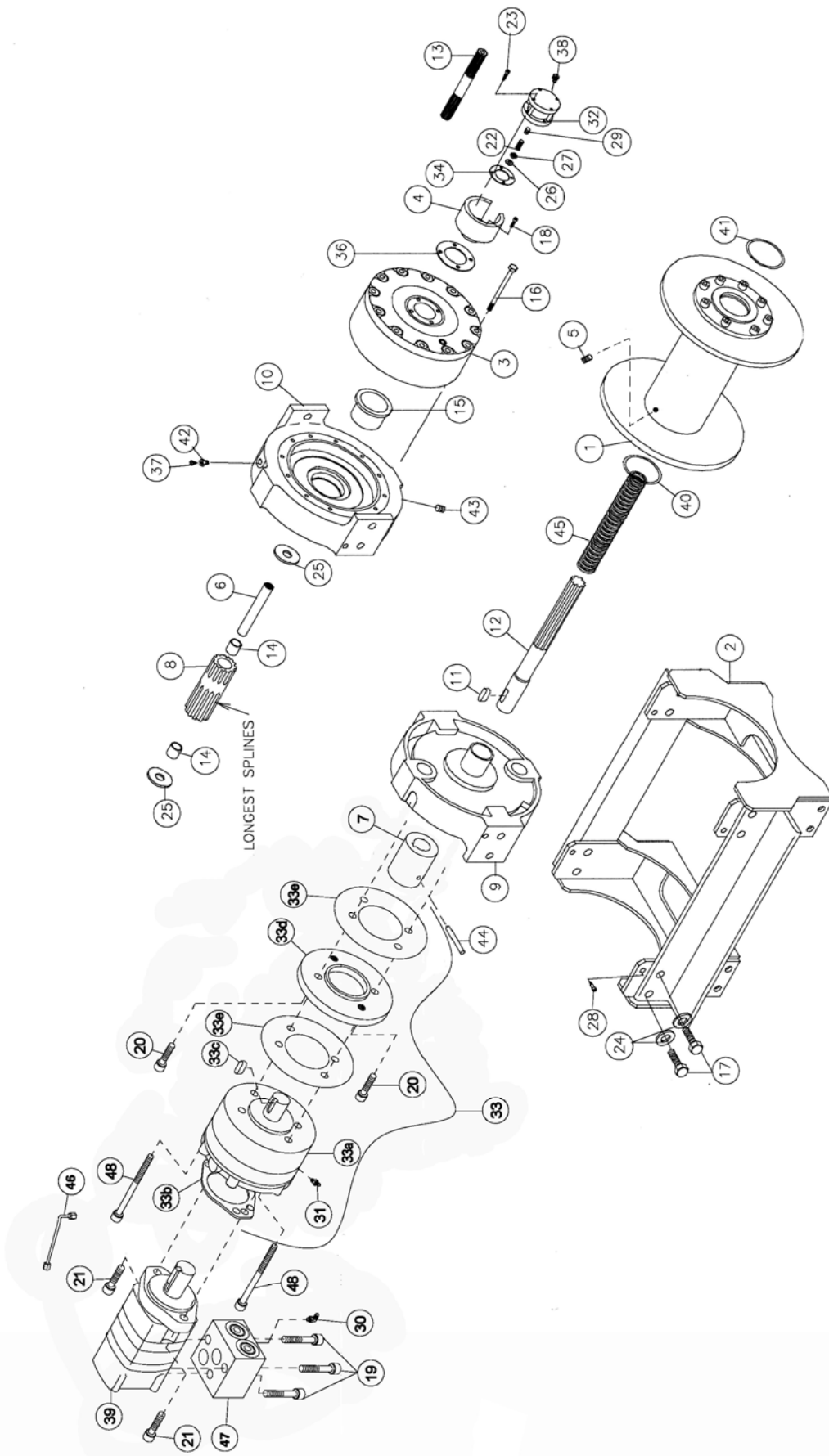

RPH 30,000 WINCH

## PARTS LIST RPH 30,0000

Item No.	Qty.	Part No.	Description	Item No.	Qty.	Part No.	Description
1	1	234167	DRUM ASSEMBLY	29	1	426045	INSERT
2	1	242156	UPRIGHT MOUNTING FRAME	30	1	432018	FITTING-HYD 7/16-20 90° ELBOX
3	1	296433	GEAR BOX	31	1	432023	FITTING 7/16-20 STRAIGHT UNION
4	1	300069	ADAPTER-AIR CYLINDER	32	1	433014	AIR CYLINDER
5	1	416059	SETSCREW - 3/8-16NC X 1/2 LG CUT POINT	33	1	438037	BRAKE ASSEMBLY
6	1	324286	COUPLING-SHAFT	33a	1		BRAKE
7	1	324287	COUPLING-BRAKE	33b	1		MOTOR GASKET*
8	1	324288	COUPLING-OUTPUT	33c	1		BRAKE SHAFT KEY
9	1	338292	END BEARING-MOTOR	33d	1		ADAPTER PLATE
10	1	338293	END BEARING-GEAR	33e	2		ADAPTER PLATE GASKET*
11	1	342081	KEY	34	1	442217*	GASKET-AIR CYLINDER
12	1	357493	SHAFT-INPUT				
13	1	358065	SHIFTER SHAFT	36	1	442216*	GASKET-ADAPTER
14	2	402119	BEARING	37	1	456008	RELIEF FITTING
15	1	412086	BUSHING-THRUST	38	1	456038	BREATHER VENT
16	12	414272	CAPSCREW 3/8-16NC X 5-1/2 LG HX HD GR5	39	1	458076	MOTOR-HYD.
17	8	414777	CAPSCREW 3/4-10NC X 1-3/4 LG HX HD GR5	40	1	462013*	QUAD RING
18	4	414864	CAPSCREW 5/16-18NC X 2-3/4 LG HX SOC HD	41	1	462050*	QUAD RING
19	3	414935	CAPSCREW 3/8-16NC X 2-1/2 LG HX SOC HD	42	1	468004	REDUCER
20	2	414947	CAPSCREW 1/2-13NC X 1 LG SOC HD	43	1	468019	PIPE PLUG
21	2	414948	CAPSCREW 1/2-13NC X 1-1/4 LG SOC HD	44	1	470089	PIN
22	1	416051	SETSCREW - 5/16-24NC X 1-1/4 LG SOC HD	45	1	494108	SPRING
23	4	416233	SETSCREW - #10-24NC X 1 LG SOC HD	46	1	509020	TUBE ASSEMBLY
24	8	418249	SETSCREW - #10-24NC X 2-1/2 LG HX SOC	47	1	516011	VALVE-CONTROL
25	2	418462	LOCKWASHER 3/4 MED SECT.	48	2	414595	CAPSCREW - 1/2-13NC X 3 1/2 HD HD GR8
26	1	418432	THRUST WASHER				
27	1	418433	THRUST WASHER				
28	4	418453	NUT - 5/16-24NC X 3/16 THK LOCK SHOULDER BOLT				

\* THESE ITEMS ARE PART OF SEAL AND GASKET KIT #246046. ALSO INCLUDED ARE (3) O-RINGS USED IN DRUM ASSEMBLY 234167, REFER TO PAGE 7.

## **LIMITED WARRANTY**

RAMSEY WINCH warrants each new RAMSEY Winch to be free from defects in material and workmanship for a period of one (1) year from date of purchase.

The obligation under this warranty, statutory or otherwise, is limited to the replacement or repair at the Manufacturer's factory, or at a point designated by the Manufacturer, of such part that shall appear to the Manufacturer, upon inspection of such part, to have been defective in material or workmanship.

This warranty does not obligate RAMSEY WINCH to bear the cost of labor or transportation charges in connection with the replacement or repair of defective parts, nor shall it apply to a product upon which repair or alterations have been made, unless authorized by Manufacturer, or for equipment misused, neglected or which has not been installed correctly.

RAMSEY WINCH shall in no event be liable for special or consequential damages. RAMSEY WINCH makes no warranty in respect to accessories such as being subject to the warranties of their respective manufacturers.

RAMSEY WINCH, whose policy is one of continuous improvement, reserves the right to improve its products through changes in design or materials as it may deem desirable without being obligated to incorporate such changes in products of prior manufacture.

If field service at the request of the Buyer is rendered and the fault is found not to be with RAMSEY WINCH's product, the Buyer shall pay the time and expense to the field representative. Bills for service, labor or other expenses that have been incurred by the Buyer without approval or authorization by RAMSEY WINCH will not be accepted



### **RAMSEY WINCH COMPANY**

Post Office Box 581510 Tulsa, Oklahoma 74158-1510  
Telephone: (918) 438-2760 FAX: (918) 438-6688

OM-912451-0307-M