

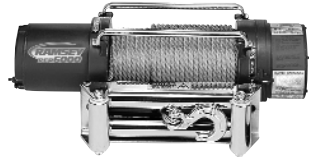

**Ramsey Winch Company
OWNER'S MANUAL
Front Mount Electric Winches**

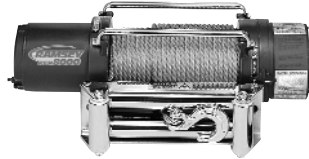

Model REP 6000



Model REP 8000



Model REP 9000

REP 6000							
PERFORMANCE FIRST LAYER OF CABLE				CABLE DRUM CAPACITY (1/4" (6 MM) DIA. CABLE) CUMULATIVE BY LAYER			
LINE PULL		LINE SPEED (FPM)	CURRENT (AMPS)		LAYER	FT.*	M*
(lbs)	(kg)	12V	12V				
0	0	25	70		1	20	6
1,000	450	21	155		2	50	15
3,000	1,350	16	240		3	80	24
5,000	2,260	10	370		4	100	30
6,000	2,710	8	440		* DEPENDS ON CABLE BEING UNIFORMLY WOUND ONTO DRUM.		

REP 8000							
PERFORMANCE FIRST LAYER OF CABLE				CABLE DRUM CAPACITY (5/16" (8 MM) DIA. CABLE) CUMULATIVE BY LAYER			
LINE PULL		LINE SPEED (FPM)	CURRENT (AMPS)		LAYER	FT.*	M*
(lbs)	(kg)	12V	12V				
0	0	18	60		1	15	4
2,000	900	15	150		2	40	12
4,000	1,810	12	220		3	70	21
6,000	2,710	9	310		4	95	28
8,000	3,620	6	420		* DEPENDS ON CABLE BEING UNIFORMLY WOUND ONTO DRUM.		

REP 9000								
PERFORMANCE FIRST LAYER OF CABLE				CABLE DRUM CAPACITY (5/16" (8 MM) DIA. CABLE) CUMULATIVE BY LAYER				
LINE PULL		LINE SPEED (FPM)		CURRENT (AMPS)		LAYER	FT.*	M*
(lbs)	(kg)	12V	24V	12V	24V			
0	0	33	25	97	35	1	15	4
2,000	900	17	15	180	75	2	40	12
4,000	1,810	13	11	260	110	3	70	21
6,000	2,710	11	9	335	140	4	95	28
9,000	4,070	8	7	420	175	* DEPENDS ON CABLE BEING UNIFORMLY WOUND ONTO DRUM.		

Ramsey performance data is compiled from actual winch testing

Congratulations

You have purchased the finest winch available in its service class. The REP 6000, REP 8000 and REP 9000 feature a highly efficient 3 stage planetary gear set. The REP 6000 and REP 8000 transmit torque from a permanent magnet D.C. motor, while the REP 9000 utilizes a series wound D.C. motor. A safe positive clutch allows free spooling for quick cable deployment. An automatic load holding brake is designed to hold the full rated capacity of the winch. It was designed and manufactured to provide you with the utmost in utility. As with any device that combines power and movement in its use, there are dangers if improperly used. At the same time, there are easier and faster ways for getting the job done if certain precautions are taken first. Please read this manual carefully. It contains useful ideas in obtaining the most efficient operation from your Ramsey Winch and safety procedures you need to know



CAUTION: Read and understand this manual before installation and operation of winch. See Safety Precautions.

Contents

Safety Precautions	2
Tips for Safe Operation.....	2
Techniques of Operation	3
Installation	4-5
Electrical Connections & Operations	8
Maintenance	8
Operating Instructions	9
Trouble Shooting Guide	10
Winch Parts List	11-15
Warranty.....	Back Cover

before beginning use. When you follow our guidelines for operation, your Ramsey Winch will give you many years of satisfying service. Thank you for choosing Ramsey. You will be glad you have one working for you.

Please Note: Ramsey REP6000, REP8000 and REP9000 Series winches are designed for front mount vehicle use. The winches are not designed for and should not be used in industrial applications (car haulers/carriers, wreckers, hoisting, etc.), and Ramsey does not warrant them to be suitable for such use. Ramsey makes a separate, complete line of winches for industrial/commercial use. Please contact the factory for further information.



Safety Precautions To Guard Against Possible Injury...

A minimum of five wraps of cable around the drum barrel is necessary to hold the rated load. Cable clamp is not designed to hold the load.

- A. Keep yourself and others a safe distance to the side of the cable when pulling under load.
- B. Don't step over a cable, or near a cable under load.
- C. Use supplied hook strap when handling hook for spooling wire rope.
- D. Don't move the vehicle to pull a load on the winch cable. This could result in cable breakage.
- E. Use a heavy rag or gloves to protect hands from burrs when handling winch cable.
- F. Apply blocks to wheels when vehicle is on an incline.
- G. Winch clutch should be disengaged when winch is not in use and fully engaged when in use.
- H. Modification, alteration or deviation to the winch should only be made by Ramsey Winch Company.
- I. Keep the duration of your pulls as short as possible. If the motor becomes uncomfortably hot to the touch, stop and let it cool for a few minutes. Do not pull more than one minute at or near rated load. Do not maintain power to the winch if the motor stalls. Electric winches are for intermittent usage and should not be used in constant duty applications.
- J. Disconnect the remote control switch from the winch when not in use. A Ramsey Part No. 282053 safety on-off switch in your vehicle is recommended.
- K. Note: Do not use winch in hoisting applications due to required hoist safety factors and features.
- L. Do not exceed maximum line pull ratings shown in tables. Shock loads must not exceed these ratings.

- M. To respool correctly, it is necessary to keep a slight load on the cable. This is accomplished by (wearing gloves) holding the cable with one hand and the remote control switch with the other, starting as far back and in the center as you can, walking up keeping load on the cable as the winch is powered in. Do not allow the cable to slip through your hand and do not approach the winch too closely. Turn off the winch and repeat the procedure until all the cable except a few feet is in. Disconnect the remote control switch and finish spooling in cable by rotating the drum by hand with clutch disengaged. On hidden winches, spool in cable under power using supplied hook strap.



Tips for Safe Operation

Don't underestimate the potential danger in winching operations. Neither should you fear them. Do learn the basic dangers and avoid them.

The uneven spooling of cable, while pulling a load, is not a problem, unless there is cable pile-up on one end of drum. If this happens, reverse the winch to relieve the load and move your anchor point further to the center of the vehicle. After the job is done you can unspool and rewind for a neat lay of the cable.

Store the remote control switch inside your vehicle where it will not become damaged. Inspect it before you plug it in.

When ready to begin spooling in, plug in remote control switch with clutch disengaged. Do not engage clutch with motor running.

Never connect the hook back to the cable. This causes cable damage. Always use a sling or chain of suitable strength as shown in the illustrations.

Observe your winch while winching, if possible, while standing at a safe distance. If you use vehicle drive to assist, stop and get out every few feet to assure the cable is not piling up in one corner. Jamming cable can break your winch.

Do not attach tow hooks to winch mounting apparatus. They must attach to vehicle frame.

When double lining during stationary winching, the winch hook should be attached to the chassis of the vehicle.

Since the greatest pulling power is achieved on the innermost layer of your winch, it is desirable to pull off as much line as you can for heavy pulls (remember, you must leave 5 wraps min. on the drum). If this is not practical, use a snatch block and double line arrangement (see illustration).

Neat, tight spooling avoids cable binding, which is caused when a load is applied and the cable is pinched between two others. If this happens, alternately power the winch in and out a few inches. Do not attempt to work a bound cable under load; free by hand.

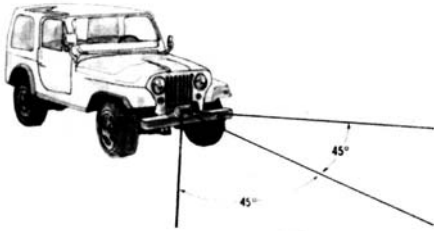

Winches equipped with cable guide fairleads can pull from several directions. Pull from an angle only to straighten up the vehicle—otherwise you can damage structural members or other parts of your vehicle and cause excess cable buildup on one end of the winch drum.

Techniques of Operation

The best way to get acquainted with how your winch operates is to make a few test runs before you actually need to use it. Plan your test in advance. Remember you hear your winch as well as see it operate. Get to recognize the sound of light steady pull, a heavy pull, and sounds caused by load jerking or shifting. Soon you will gain confidence in operating your winch and its use will become second nature with you.

Your winch will not only pull your vehicle up or ease your vehicle down a steep grade, it will also pull another vehicle or a load while your vehicle is anchored in a stationary position. The following sketches show you a few techniques.

When pulling a heavy load, place a blanket, jacket or tarpaulin over the cable five or six feet from the hook. It will slow the snap back in the event of a broken cable. Also open the vehicle hood for additional protection.



For basic self-recovery, anchor to a tree or heavy rock. When anchoring to a tree, always use a tree trunk protector.



Stakes driven in solid earth and chained together make a good anchor point for self-recovery when no solid anchor point is available.

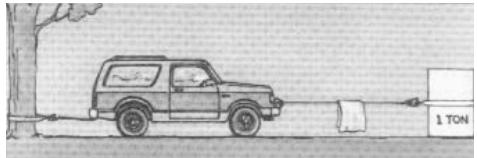

For a direct pull of 2000 lbs., hitch truck to a tree or solid anchor, and take out of gear.

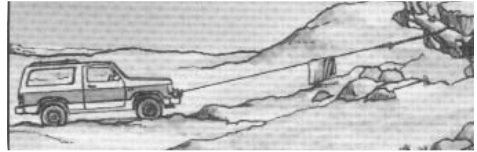

For a solid anchor, bury a log with earth or sand or place it in a deep ravine.

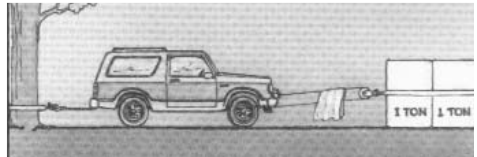

To double the pull, use 2-part line with snatch block and tie off to chassis. Take out of gear.

Use the vehicle wheel power to help the winch, but don't overtake the winch line. Plan your pull. You can't always hook up and pull out in one step. Examine all the areas for anchoring possibilities as well as leverage situations, direction and goal.

Installation

The winches shown in this owner's manual are solely and exclusively designed for vehicle mounted, non-industrial applications. All other applications will void warranty.

Note: For specific bull-bar applications, the shifter lever on the winch may need to be repositioned. Refer to pages 6-7 for instructions in how to do this.

It is very important that the winch be mounted on a flat surface so that the three major sections (the motor end, the cable drum and the gear housing end) are properly aligned. It is recommended that Ramsey kits be used to mount the winch. They are designed to align the winch and distribute up to the full rated load evenly, to avoid possible damage to the winch or vehicle. Note: If recommended mounting is not used, a kit of equal design must be used.

Also available for mounting the REP winches are winch mounting channels, short length (23.63") #408052 (black), medium length (30.00") #408120 (black) and long length (36.00") #408101 (black). It is recommended that a Ramsey mounting channel be used in all non-Ramsey mountings.

Note: See the following separate sections for attaching the wiring to the motor and solenoid for the REP 6000/8000, REP 9000 12V, and REP 9000 24V models. The combined installation instructions resume on the following page.

REP 6000/8000

When mounting winch, attach solenoid wires to motor terminals at end of motor. TIGHTEN NUTS ON MOTOR TERMINALS SECURELY (see FIGURE 1). Attach solenoid to mounting holes at end of long channel (see FIGURE 1) or use solenoid

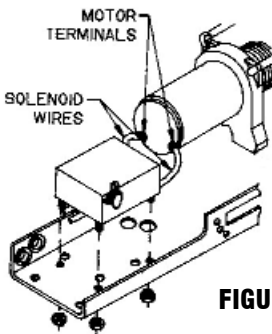

FIGURE 1

clamp to attach solenoid assembly to winch motor (see FIGURE 2). Position solenoid at about a 45° angle for clearance of lower winch guard tube of kit. TIGHTEN CLAMP SECURELY.

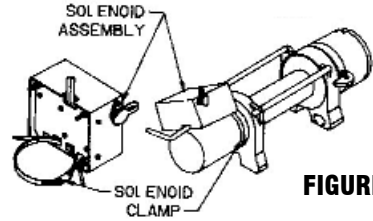

FIGURE 2

REP 9000 12V

When mounting winch, connect labeled motor leads coming from solenoid assembly to appropriately marked motor terminals. TIGHTEN NUTS ON MOTOR TERMINALS SECURELY (see FIGURE 3). Attach solenoid ground wire to grounding bolt located at bottom of motor (Battery ground wire is already installed to grounding bolt on motor.)

Use solenoid clamp, as shown in FIGURE 2, to secure solenoid assembly to winch motor. If installing in combo mounting kit, position at about a 45° angle for clearance of lower winch guard tube in kit. Be sure that clamp is clear of motor terminals at bottom of motor. TIGHTEN CLAMP SECURELY.

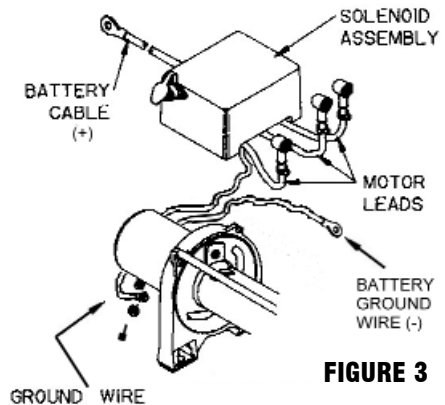
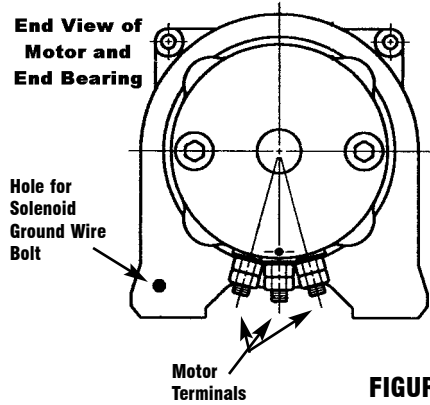

FIGURE 3

REP 9000 24V

When mounting winch, connect labeled motor leads coming from solenoid assembly to appropriately marked motor terminals. **TIGHTEN NUTS ON MOTOR TERMINALS.** Attach solenoid ground to #10 Capscrew located on vertical surface of motor end bearing (See FIGURE 4). Use solenoid clamp, as shown in FIGURE 2, to secure solenoid assembly to winch motor. If installing in combo mounting kit, position at about a 45° angle for clearance of lower winch guard tube in kit. Be sure that clamp is clear of motor terminals at bottom of motor. **TIGHTEN CLAMP SECURELY.**



Attach fairlead to channel using hardware furnished with winch (see FIGURE 5). Attach winch to channel. Place (4) flat washers and nuts into pockets of winch mounting feet and thread capscrews with lock washers through mounting holes in channel and into hardware in winch feet.

Substitution of attaching hardware items (bolts, nuts or washers) different from those supplied with your winch and mounting kit can lead to failure causing damage or serious injury (use SAE grade 5 bolts or better and torque to 34 ft. lbs.)

Place end of drum cable through fairlead and attach cable hook. Use clevis pin and cotter pin (see FIGURE 5).

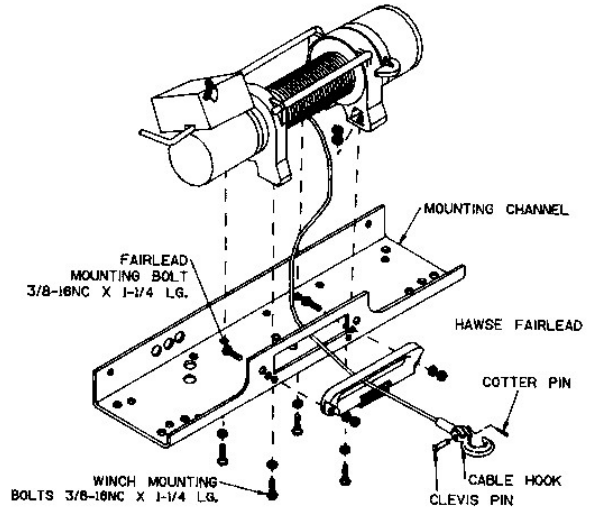

Repositioning Shifter for Specific Bull Bar Applications

Note: The shifter is positioned correctly for most applications. It will only need to be repositioned as necessary for specific bull bar applications.

Refer to the Parts List and Exploded Parts Diagram for your specific winch elsewhere in this owner's manual.

1. Position winch as shown in Figure 6. Remove screws from tiebars. You may be able to loosen the screws at the motor end without removing them. Pull the Gear Housing assembly from the drum and shaft and set it down on the work bench with the Gear Housing Cover up. Remove the drum bushing from the Gear Housing assembly or the end of the drum. Set aside.

2. Remove (6) capscrews from the Gear Housing Cover. Holding the Gear Housing assembly, flip it over and set it on the workbench.

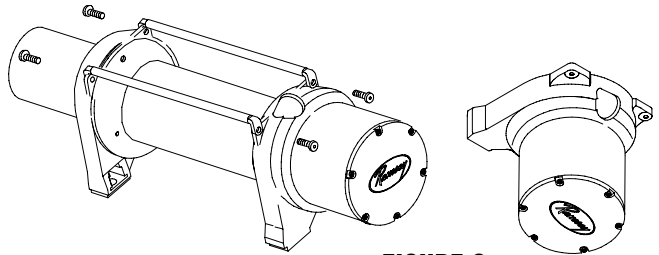

FIGURE 6

3. Gently lift the Gear Housing assembly, working the gears, bushings, etc. that are inside the Gear Housing out so that they are left stacked on the workbench. See Figure 8.

4. Turn the Gear Housing assembly over and set on workbench. Remove the Retainer (item #37) by removing six capscrews (item #21) from Gear End Bearing (item 13). Once the retainer is removed, the Ring Gear (item #10), Cam Ring (item #36), and Locking Ring (item #34) can be lifted off the end bearing.

Remove the six springs (item #38) from the end bearing.

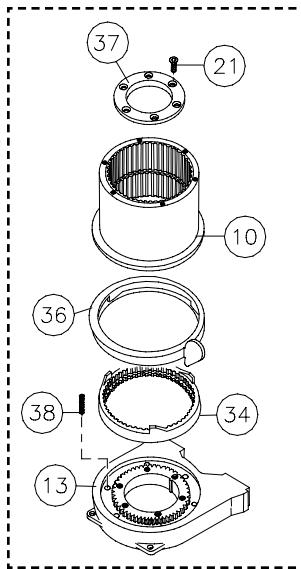

FIGURE 7

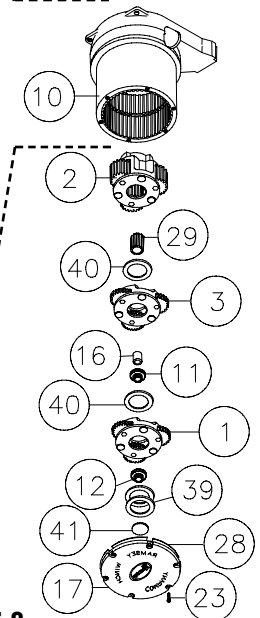

FIGURE 8

5. Determine position shifter knob needs to be for your application. **Note:** Shifter knob cannot be positioned too low or it will interfere with the feet on the Gear End Bearing (see Range of Position in Figure 9).

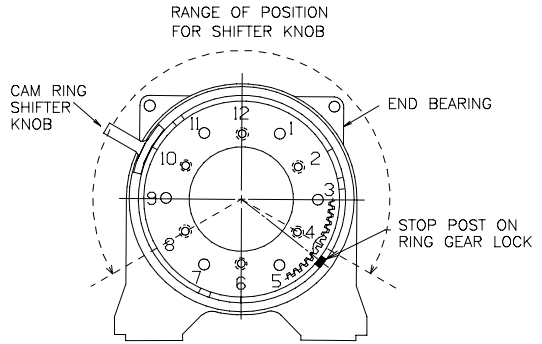

FIGURE 9

6. To position the shifter knob, place locking ring in end bearing with stop post approximately 180° from where shifter knob needs to be positioned. Place cam ring over locking ring in proper position and confirm that shifter knob will move from engaged to disengaged position without interference. Mark position of stop post on end bearing.

7. Remove cam ring and locking ring from end bearing. Insert springs (item #38) into end bearing. When you replace the locking ring (item #34) over the springs, be sure the springs compress down into their recesses, and don't bend sideways.

8. Reassemble Gear Housing as shown in Figure 7. Make sure locking ring is positioned with stop post at marked location. The capscrews (item #38) for the retainer should be tightened to 40-45 in-lbs. **Do not over-tighten.**

9. Place Gear Housing over the stacked gears, etc. that you removed in step 3. Gently work the housing over the stack, turning it as needed to mesh the planetary gears with the ring gear in the housing. Once they are all in the housing, flip the assembly over. Align the Gear Housing Cover and gasket with the holes in the ring gear. Replace the (6) capscrews that hold the Gear Housing Cover onto the Gear Housing. Tighten securely.

10. Move the Shifter to the Disengaged position.

11. Turn the Gear Housing over and set it on the work bench with the Gear Housing Cover down. See Figure 10.

12. Install the drum bushing into the Gear Housing, confirming that the slot in the bushing is aligned with the key in the end bearing. Pick up the rest of the winch (drum and motor end), and holding the drum, lower the winch onto the gear end. Stab the shaft into the gear end--you may need to turn the drum slightly to get the shaft to go all the way in.

13. Place the tiebars on the motor end and gear end and fasten using (4) screws. Tighten securely.

14. Once the winch is reassembled, turn it so that it is sitting on its feet. Confirm that the cable will freespool when the shifter is in the Disengaged position. Connect up the winch temporarily and confirm that the cable spools when the shifter is in the Engaged position.

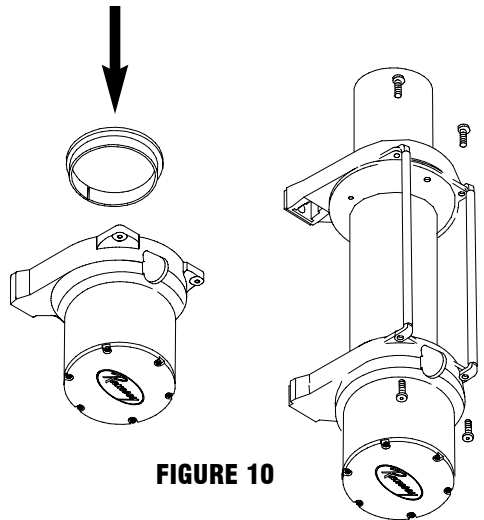

FIGURE 10

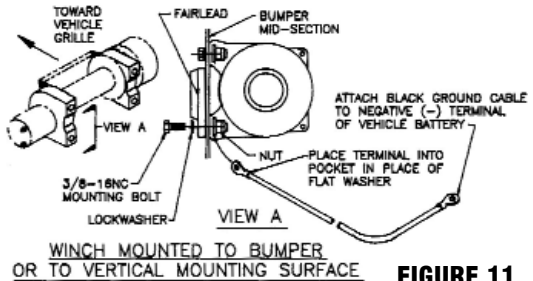
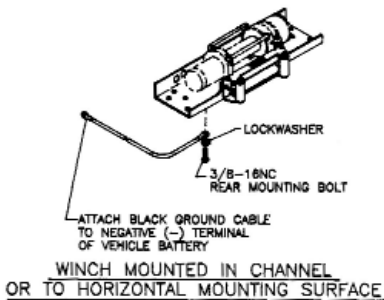

FIGURE 11

Electrical Connections and Operations

For normal self-recovery work, your existing electrical system is adequate. Your battery must be kept in good condition. A fully charged battery and proper connections are essential. Run the vehicle engine during winching operations to keep battery charged.

REP-6000/REP-8000/REP 9000 12V Electrical Connections

Route red and black battery cables up to battery. CAUTION: BE SURE BATTERY CABLES ARE NOT DRAWN TAUT ACROSS ANY SURFACES WHICH COULD POSSIBLY DAMAGE THEM. Connect red cable to positive (+) battery terminal and black cable to negative (-) terminal.

REP-9000 24V Electrical Connections

Route battery cable up to battery. CAUTION: BE SURE BATTERY CABLES ARE NOT DRAWN TAUT ACROSS ANY SURFACES WHICH COULD POSSIBLY DAMAGE THEM. Connect red cable to positive (+) battery terminal (see Figure 3). Connect black ground cable to negative (-) terminal of battery and to winch mounting bolt on motor end of winch (see Figure 6 on following page).

The remote control switch is waterproof. It has push button stations on either side. It is designed this way to prevent quick winch reversals, which lead to solenoid failure. Make sure the motor has stopped fully before reversing. To actuate winch simply plug remote control switch into receptacle in black solenoid cover of winch. Run winch forward and reverse to check connection and to determine winch operating directions. Snap

appropriate "IN" and "OUT" disc into proper thumb cavity. The switch is also color coded to aid you in not having to guess at the direction your winch will run. DO NOT LEAVE SWITCH PLUGGED IN WHEN WINCH IS NOT IN USE.

Corrosion on electrical connections will reduce performance or may cause a short. Clean all connections especially in remote control switch and receptacle. In salty environments use a silicone sealer to protect from corrosion.

Maintenance

All moving parts in the winch are permanently lubricated with high temperature lithium grease at the time of assembly. Under normal conditions factory lubrication will suffice. Lubricate cable periodically using light penetrating oil. Inspect for broken strands and replace if necessary with Ramsey part number listed in Parts List. If the cable becomes worn or damaged, it must be replaced.

Unwind the new cable by rolling it out along the ground, to prevent kinking. Remove old cable and observe the manner in which it is attached to the cable drum flange.

Before installing the new cable assembly, make sure end of cable is squarely cut and wrapped with tape to prevent fraying. Form a short 90° bend (approximately 1/2") on end of the cable.

Position the cable drum so that the large 13/32" diameter hole in the motor end drum flange is approximately on the top. Insert the bent end of cable into the 13/32" hole in the drum flange and then carefully run the winch in the "reel in" direction approximately 3/4 revolution until the 1/4" diam-

eter threaded hole in the drum flange is on top. Secure the cable to the drum flange using cable anchor and capscrew shown in the parts drawing. Securely tighten the capscrew, but do not over-tighten.

Wind 5 wraps of cable onto the drum. Winch on the rest of the cable by pulling in a light load to keep the tension constant. Allow the cable to swivel by using a length of chain or a block between the cable hook and the load.

Operating Instructions

The winch clutch allows rapid unspooling of the wire rope for hooking onto the load or anchor point. The clutch is operated by the shifter tab located on the gear-housing end of the winch as follows:

1. To disengage the clutch, move the clutch shifter tab to the "OUT" position. Wire rope may now be free-spooled off the drum.
2. To engage the clutch, move the clutch shifter tab into the "IN" position. The winch is now ready for pulling.

Ramsey Electric Winches Troubleshooting Guide

CONDITION	POSSIBLE CAUSE	CORRECTION
MOTOR RUNS IN ONLY ONE DIRECTION	(1) Defective solenoid or stuck solenoid (2) Defective remote control switch	(1) Jar solenoid to free contacts. Check by applying 12 volts to coil terminal (it should make an audible click when energized) (2) Disengage winch clutch, remove remote control switch plug from the socket and jump pins at 8 and 4 o'clock. Motor should run. Jump pins at 8 and 10 o'clock. Motor should run
MOTOR RUNS EXTREMELY HOT	(1) Long period of operation	(1) Cooling-off periods are essential to prevent overheating
MOTOR RUNS, BUT WITH INSUFFICIENT POWER, OR WITH LOW LINE SPEED	(1) Insufficient battery (2) Bad connection (3) Insufficient charging system	(1) Check battery terminal voltage under load. If 10 volts or less, replace or parallel another battery to it (2) Check battery cables for corrosion; clean and grease (3) Replace with larger capacity charging system
MOTOR RUNS, BUT DRUM DOES NOT TURN	(1) Clutch not engaged	(1) If clutch engaged but symptom still exists, it will be necessary to disassemble winch to determine cause and repair
MOTOR WILL NOT OPERATE	(1) Defective solenoid or stuck solenoid (2) Defective remote control switch (3) Defective motor (4) Loose connections	(1) Jar solenoid to free contacts. Check solenoid by applying 12 volts to coil terminal (it should make an audible click when energized) (2) Disengage winch clutch, remove remote control switch plug from the socket and jump pins at 8 and 4 o'clock. Motor should run. Jump pins at 8 and 10 o'clock. Motor should run. (3) If solenoids operate, check for voltage at armature post; replace motor (4) Tighten connections on bottom side of hood and on motor
MOTOR WATER DAMAGED	(1) Submerged in water or water from high pressure car wash	(1) Allow to drain and dry thoroughly, then run motor without load in short bursts to dry windings.
CABLE DRUM WILL NOT FREESPOOL OR IS DIFFICULT TO FREESPOOL	(1) Clutch not disengaged (2) Winch not mounted squarely causing end bearing to bind drum (3) Some or all of the (6) 414861 flat head capscrews attaching the 479007 ring gear retainer are too tight	(1) Check clutch operation according to nameplate. Make sure clutch shifter knob is fully at "OUT" position. (2) Check mounting to see that installation instructions on page 4 have been followed. (3) Remove the gear housing cover, 413018, and all gears from inside the gear housing. Disengage the clutch and check to see that the ring gear will rotate by hand. If it will not, using a hex (allen) wrench, slightly loosen all the capscrews and then snugly re-tighten them in cross-cross pattern, but do not over tighten. The ring gear must rotate by hand. Re-assemble the winch.

REP 6000

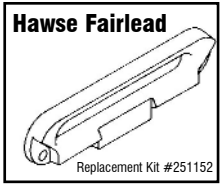

Included with: REP 6000 H

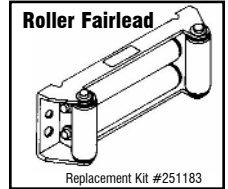

Included with: REP 6000 R

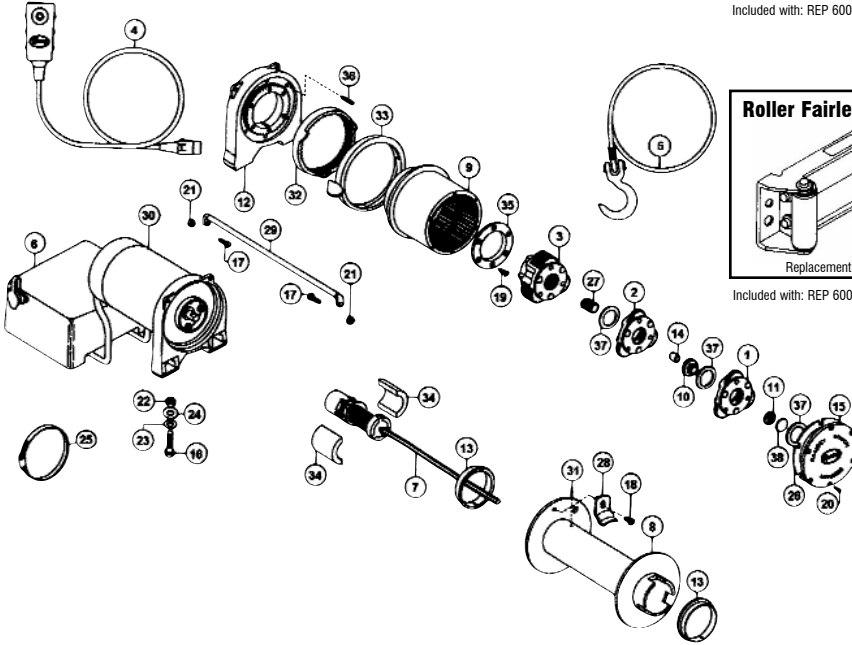

REP 6000 PARTS LIST

Item No.	Qty.	Parts No.	Description	Item No.	Qty.	Parts No.	Description
1	1	247009	Gear Carrier Ass'y.—Input	20	6	416273	Screw #6—32NCx3/8 Lg. Fil. Hd.
2	1	247007	Gear Carrier Ass'y.—Intermediate	21	4	418018	Nut 1/4—20NC Hx. Reg. Elastic Stop
3	1	247008	Gear Carrier Ass'y.—Output	22	4	418035	Nut 3/8—16NC Hx. Reg. Z/P
4	1	251110	Switch Ass'y	23	4	418177	Lockwasher 3/8 ID Med. Sect. Plated
5	1	251228	Cable Assembly-100' 1/4" (6MM) Dia.	24	4	418181	Washer—Flat 3/8 ID S.A.E., Plated
6	1	278154	Solenoid Ass'y	25	1	424023	Clamp
7	1	296181	Brake/Shaft Ass'y	26	1	442207	Gasket
8	1	332128	Drum—Cable	27	1	444048	Gear—Output, Sun
9	1	334143	Gear—Ring	28	1	448071	Cable Anchor
10	1	334147	Gear—Intermediate, Sun	29	2	448049	Tie Bar
11	1	334154	Gear—Input, Sun	30	1	458109	Motor/End Bearing Ass'y.
12	1	338249	End Bearing	31	1	470053	Roll Pin 1/8 Dia. x 3/8
13	2	412056	Bushing—Drum	32	1	477002	Locking Ring
14	1	412061	Bushing—Shaft	33	1	477003	Cam Ring
15	1	413018	Cover—Gear Housing	34	2	477004	Ring—Half
16	4	414316	Capscrew 3/8—16NCx1-1/4Lg.Hx.Hd.Gr.5.Z/P	35	1	479007	Retainer—Ring Gear
17	4	414829	Capscrew 1/4—20NCx1 Lg. Soc. Button Hd.	36	6	494077	Spring
18	1	414830	Capscrew 1/4—20NCx3/8 Lg. Soc. Button Hd.	37	3	518020	Thrust Washer
19	6	414861	Capscrew 1/4—20NCx3/4 Lg. Flat Hd. Soc. NYLOK	38	1	518027	Thrust Disc

REP 8000

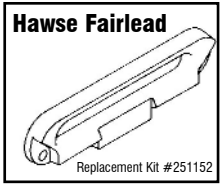

Included with: REP 8000 H

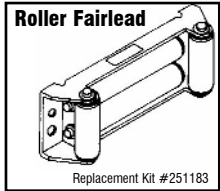

Included with: REP 8000 R

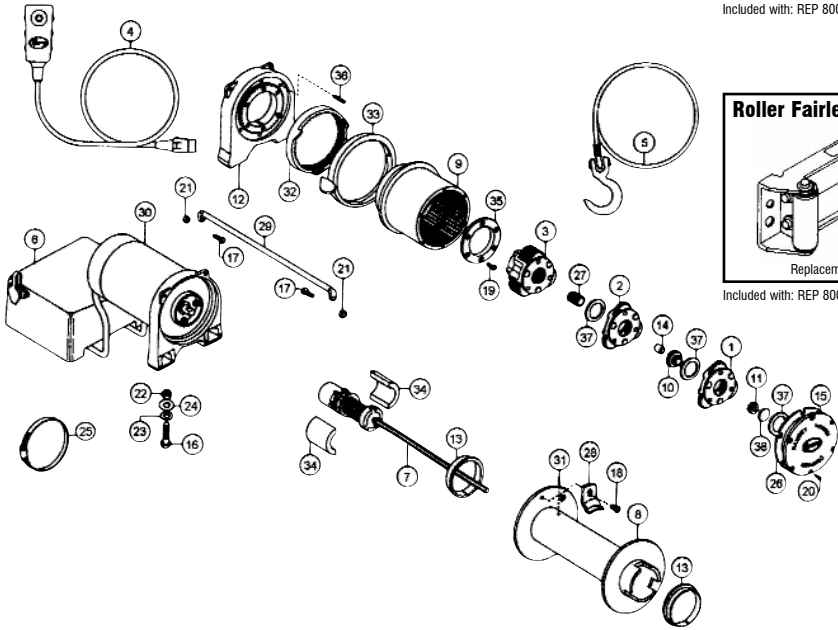

REP 8000 PARTS LIST

Item No.	Qty.	Parts No.	Description	Item No.	Qty.	Parts No.	Description
1	1	247004	Gear Carrier Ass'y.—Input	20	6	416273	Screw #6—32NCx3/8 Lg. Fil. Hd.
2	1	247007	Gear Carrier Ass'y.—Intermediate	21	4	418018	Nut 1/4—20NC Hx. Reg. Elastic Stop
3	1	247008	Gear Carrier Ass'y.—Output	22	4	418035	Nut 3/8—16NC Hx. Reg. Z/P
4	1	251110	Switch Ass'y	23	4	418177	Lockwasher 3/8 ID Med. Sect. Plated
5	1	251118	Cable Assembly-95' 5/16" (8MM) Dia.	24	4	418181	Washer—Flat 3/8 ID S.A.E., Plated
6	1	278155	Solenoid Ass'y	25	1	424023	Clamp
7	1	296181	Brake/Shaft Ass'y	26	1	442207	Gasket
8	1	332128	Drum—Cable	27	1	444048	Gear—Output, Sun
9	1	334143	Gear—Ring	28	1	448046	Cable Anchor
10	1	334147	Gear—Intermediate, Sun	29	2	448049	Tie Bar
11	1	334153	Gear—Input, Sun	30	1	458109	Motor/End Bearing Ass'y.
12	1	338249	End Bearing	31	1	470053	Roll Pin 1/8 Dia. x 3/8
13	2	412056	Bushing—Drum	32	1	477002	Locking Ring
14	1	412061	Bushing—Shaft	33	1	477003	Cam Ring
15	1	413018	Cover—Gear Housing	34	2	477004	Ring—Half
16	4	414316	Capscrew 3/8—16NCx1-1/4Lg.Hx.Hd.Gr.5,Z/P	35	1	479007	Retainer—Ring Gear
17	4	414829	Capscrew 1/4—20NCx1 Lg. Soc. Button Hd.	36	6	494077	Spring
18	1	414830	Capscrew 1/4—20NCx3/8 Lg. Soc. Button Hd.	37	3	518020	Thrust Washer
19	6	414861	Capscrew 1/4—20NCx3/4 Lg. Flat Hd. Soc. NYLOK	38	1	518027	Thrust Disc

REP 9000

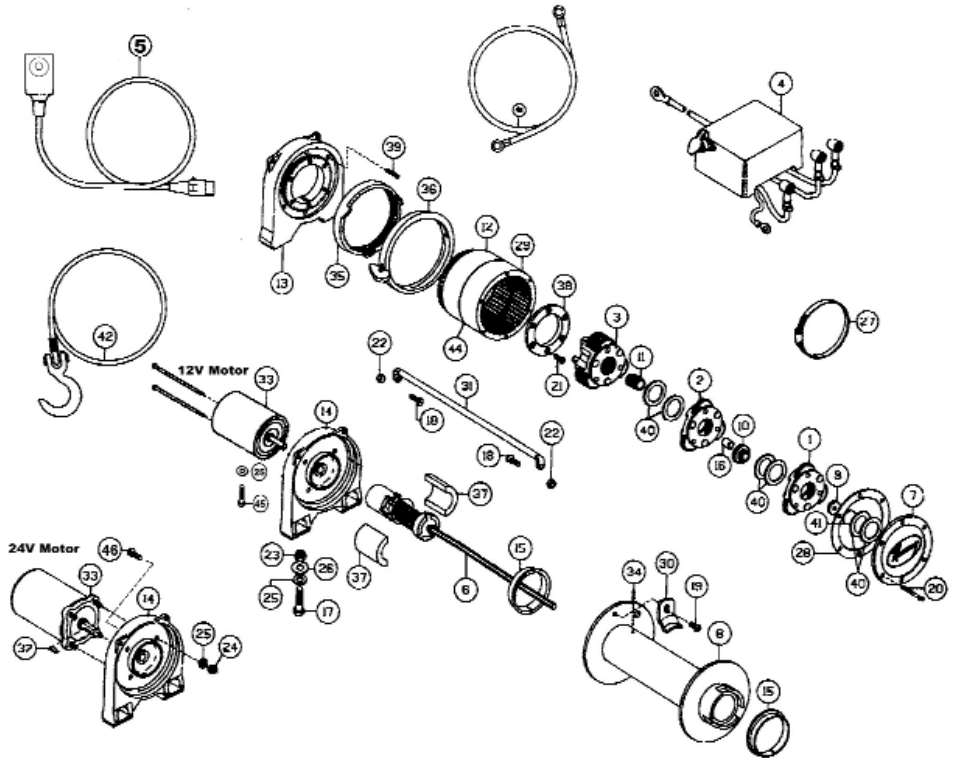

REP 9000 PARTS LIST

Item No.	Qty.	Parts No.	Description	Item No.	Qty.	Parts No.	Description
1	1	247009	Gear Carrier Ass'y—Input	23	4	418035	Nut 3/8—16NC Hx. Reg. Z/P
2	1	247022	Gear Carrier Ass'y—Intermediate	24	4	418040	Nut 3/8—24NC Hx. Reg. Z/P
3	1	247023	Gear Carrier Ass'y—Output	25	5	418177	Lockwasher 3/8 Med. Sect. Z/P 12V
4	1	278158	Solenoid Ass'y—12V	8	418177	Lockwasher 3/8 Med. Sect. Z/P 24V	
1	1	278096	Solenoid Ass'y—24V	26	5	418181	Washer—Flat 3/8 ID S.A.E. Z/P
5	1	251110	Switch Ass'y	27	1	424023	Clamp
6	1	296181	Brake/Shaft Ass'y—12V	28	1	442208	Gasket—Cover
1	1	296385	Brake/Shaft Ass'y—24V	29	1	444077	Gear—Ring, Input
7	1	328138	Cover—Gear Housing	30	1	448046	Cable Anchor
8	1	332193	Drum—Cable	31	2	448049	Tie Bar
9	1	334154	Gear—Input Sun	32	1	450001	Key—24V.
10	1	334147	Gear—Intermediate Sun	33	1	458114	Motor—Electric 12V
11	1	334170	Gear—Output Sun	1	458005	Motor—Electric 24V	
12	1	334171	Gear—Ring, Output	34	1	470053	Roll Pin 1/8 Dia. x 3/8 Lg.
13	1	338332	End Bearing	35	1	477002	Locking Ring
14	1	296534	End Bearing—Motor—12V	36	1	477003	Cam Ring
1	1	338282	End Bearing—Motor—24V	37	2	477004	Ring—Half
15	2	412056	Bushing—Drum	38	1	479007	Retainer—Ring Gear
16	1	412061	Bushing—Shaft	39	6	494077	Spring
17	4	414316	Capscrew 3/8—16NCx1-1/4Lg.Hx.Hd.Gr.5,Z/P	40	6	518020	Thrust Washer
18	4	414823	Capscrew 1/4—20NCx1 Lg. Soc. Button Hd.	41	1	518027	Thrust Disc
19	1	414830	Capscrew 1/4—20NCx3/8 Lg. Soc. Button Hd.	42	1	251118	Cable Assembly
20	6	414868	Capscrew 1/4—20NCx2-1/2 Lg. Flat Hd. Soc. NYLOK	43	1	289141	Cable—Ground
21	6	414861	Capscrew 1/4—20NCx3/4 Lg. Flat Hd. Soc. NYLOK	44	1	442219	Gasket
22	4	418018	Nut 1/4—20NC Hx. Elastic Stop	45	1	414370	Capscrew 3/8-24NF x 1/2 HX HD ZP GR5
				46	1	416212	Screw #10-24NC x 3/8 Lg Hx Soc Hd ZP

Solenoid Assembly Parts List REP 6000/REP 8000

278154—REP 6000

278155—REP 8000

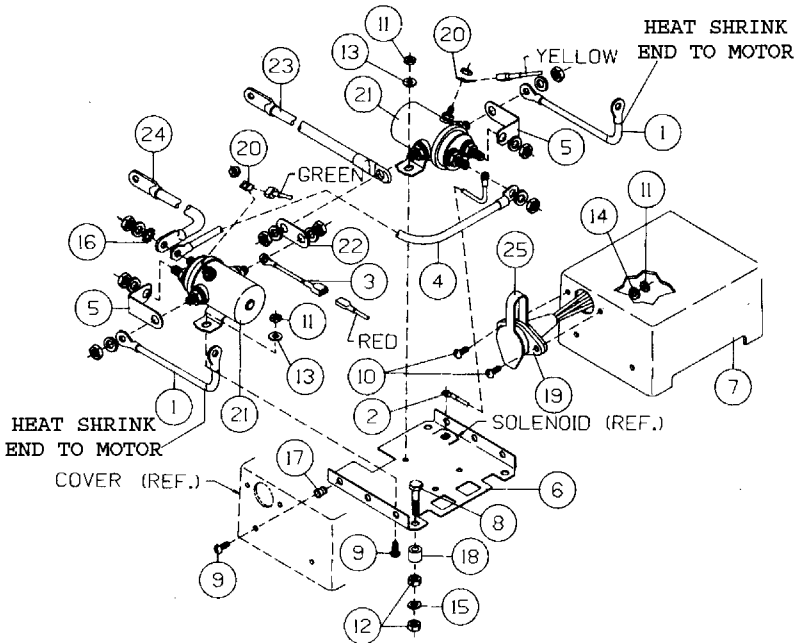

Note: All unidentified hardware comes supplied with the solenoid.

Item No.	Qty. Req'd	Part No.	Description
1	2	289168	Wire Assembly—Black 4 Ga. x6" Lg.
2	1	289090	Wire Assembly—Black 10 Ga. x3" Lg
3	1	289091	Wire Assembly—Black 16 Ga. x 1-1/2" Lg
4	1	289169	Wire Assembly—Black 4 Ga. x3-1/2" Lg
5	2	364002	Strap—Copper
6	1	408102	Bracket
7	1	413024	Cover—Solenoid
8	3	414053	Capscrew 1/4—20NCx1-1/4Lg.Hx.Hd. Z/P
9	7	416216	Screw #10—24NCX 1/2" Lg. Rd. Hd. Z/P
10	2	416227	Screw #10—24NCX 3/4" Lg. Truss Hd. Black
11	6	418004	Nut—Hx. Reg. #10—24NC Z/P
12	6	418014	Nut—Hx. Reg. 1/4—20NC Z/P
13	4	418140	Washer #10 SAE Flat Z/P
14	2	418141	Lockwasher #10 Med. Sect. Z/P
15	3	418149	Lockwasher 1/4 Med. Sect. Z/P
16	1	418165	Washer 5/16 Shakeproof External Teeth
17	3	418411	Nutsert #10—24NC
18	3	418514	Spacer
19	1	430013	Connector Female—Molded
20	2	440071	Terminal Tab
21	2	440110	Solenoid
22	1	440111	Strap—Copper
23	1	289015	Wire Assembly—Battery Red 72" (REP 6000)
	1	440112	Wire Assembly—Battery Red 60" (REP 8000)
24	1	289141	Wire Assembly—Battery Red 72" (REP 6000)
	1	440113	Wire Assembly—Battery Red 60" (REP 8000)
25	1	482029	Cover—Female Connector

Solenoid Assembly Parts List REP 9000

278158—12V

278096—24V

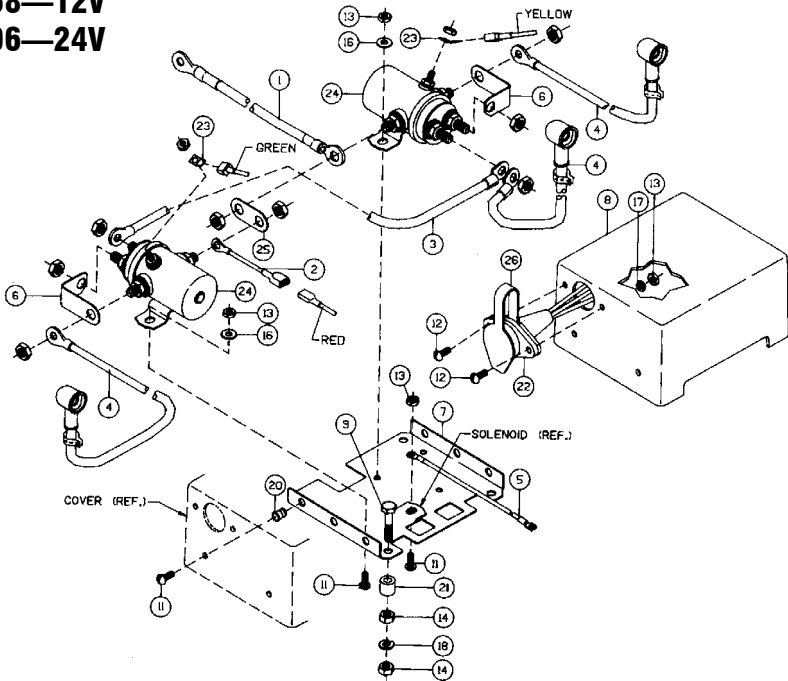

Note: All unidentified hardware comes supplied with the solenoid.

Item No.	Qty. Req'd	Part No.	Description
1	1	289015	Battery Cable
2	1	289091	Wire Assembly—Black 16 Ga. x 1-1/2" Lg.
3	1	289092	Wire Assembly—Black 6 Ga. x 3-1/2" Lg
4	3	289171	Wire Assembly—Motor Lead—12V
	3	289115	Wire Assembly—Motor Lead—24V
5	1	289208	Wire Assembly—Ground 12v
	1	289209	Wire Assembly—Ground 24v
6	2	364002	Strap—Copper
7	1	408102	Bracket
8	1	413024	Cover—Solenoid
9	3	414053	Capscrew 1/4—20NCx1-1/4Lg.Hx.Hd. Z/P
11	7	416216	Screw #10—24NCX 1/2" Lg. Rd. Hd. Z/P
12	2	416227	Screw #10—24NCX 3/4" Lg. Truss Hd. Black
13	6	418004	Nut—Hx. Reg. #10—24NC Z/P
14	6	418014	Nut—Hx. Reg 1/4—20NC Z/P
16	3	418140	Washer #10 SAE Flat Z/P
17	2	418141	Lockwasher #10 Med. Sect. Z/P
18	3	418149	Lockwasher 1/4 Med. Sect. Z/P
20	3	418411	Nutsert #10—24NC
21	3	418514	Spacer
22	1	430013	Connector Female—Molded
23	2	440071	Terminal Tab
24	2	440110	Solenoid—12V
	2	440114	Solenoid—24V
25	1	440111	Strap—Copper
26	1	482029	Cover—Female Connector

Warranty Information

Ramsey Winches are designed and built to exacting specifications. Care and skill go into every winch we make. If the need should arise, warranty procedure is outlined on the back of your self-addressed, postage paid warranty card. Please read and fill out the enclosed warranty card and send it to Ramsey Winch Company. If you have any problems with your winch, please follow instructions for prompt service on all warranty claims.

Limited Lifetime Warranty

Ramsey Winch offers a limited lifetime warranty for each new Ramsey winch against manufacturing defects in workmanship and materials on all manufactured components.

Warranty registration cards for each winch must be submitted at the time of purchase or within 30 days. Warranty will only be valid for the original purchaser of the winch and installed on the vehicles with which they were originally registered.

New cable assemblies are warranted against defects in workmanship and materials. No warranty applies after initial use.

All Ramsey mounting kits and other accessories carry a 1-year limited warranty against defects in materials and workmanship.

Chrome finish warranted for one year against manufacturing defects. Cracking, scratching or corrosion caused by winching not covered by warranty.

This warranty is void if winch is used in commercial/industrial applications other than front mount self recovery.

Electrical components consisting of motors, solenoids, wiring, wire connectors, and associated parts carry a limited 1-year warranty. Battery isolators carry a 90-day limited warranty.

An optional extended 2-year limited warranty for all electrical components may be purchased.

The obligation under this warranty, statutory or otherwise, is limited to the replacement or repair at the manufacturer's factory, or at a point designated by the manufacturer, of such part as shall appear to the manufacturer, upon inspection of such part, to have been defective in material or workmanship. This Warranty does not obligate Ramsey Winch Company to bear the cost of labor or transportation charges in connection with the replacement or repair of defective parts, nor shall it apply to a product upon which repairs or alterations have been made, unless authorized by the manufacturer, or for equipment misused, neglected or improperly installed.

Important notice: To the fullest extent permitted by applicable law, the following are hereby excluded and disclaimed: 1. All warranties of fitness for a particular purpose; 2. All warranties of merchantability; 3. All claims for consequential or incidental damages. There are no warranties that extend beyond the description that appears on the face hereof.

Some states do not allow the above exclusions or disclaimers in consumer transactions and as such this disclaimer/exclusion may not apply to your particular case.

To the extent such warranties of fitness for a particular purpose or merchantability are deemed to apply to this product, they exist only for so long as the express limited warranty elsewhere set forth is in existence.

Ramsey Winch Company makes no warranty in respect to accessories, same being subject to the warranties of their respective manufacturers.

Ramsey Winch Company, whose policy is one of continuous product improvement, reserves the right to improve any product through changes in design or materials as it may deem desirable without being obligated to incorporate such changes in products of previous manufacture.

If field service at the request of the buyer is rendered and the fault is found not to be with Ramsey Winch Company's product, the buyer shall pay the time and expense of the field representative. Bills for service, labor or other expenses which have been incurred by the buyer without express approval or authorization by Ramsey Winch Company will not be accepted.

This warranty gives you specific legal rights and you may also have other legal rights which vary from state to state.



RAMSEY WINCH COMPANY
P.O. BOX 581510 • TULSA, OKLAHOMA 74158-1510 • USA
PHONE (918)438-2760 • FAX (918)438-6888 • <http://www.ramsey.com>