



Doosan Infracore  
Construction Equipment

# DX700LC

Engine Power : SAE J1349,net 345kw(463 HP)@1,800 rpm

Operational Weight : 70,100kg - STD.

Bucket capacity(SAE): 3.0 ~4.5 m<sup>3</sup>











## A New Model DX 700 LC Hydraulic Excavator :

Novel Increased production and improved fuel economy is attributed to the electronic optimization of the hydraulic system and the new generation DOOSAN DX700LC engine (ISUZU Tier-3 Stage). Improved ergonomics increases comfort and excellent all round visibility ensuring a safe and pleasant working environment. Improved reliability is achieved through the use of high performance materials combined with new methods of structural stress analysis, and leads to increased component life expectancy, thus reducing running costs. Reduced maintenance increases the availability and reduces operating costs of the excavator.



## Performance



The performance of the DX 700LC has a direct effect on its productivity. Its new "Common Rail" engine and new e-EPOS controlled hydraulic system have combined to create an unbeatable hydraulic excavator, with a cost/performance ratio that makes the DX 700 LC even more appealing.





## DOOSAN DX 700LC ENGINE

Maker & Model	ISUZU MOTORS AH-6WG1XYSC-01
Cooling Fan	Not Installed
Alternator	24V, 80A
Air Cleaner	Installed
Muffler	Installed
Rated Horse Power	345 kW(469 PS) @ (DIN 6271)
	345 kW(463 PS) @ (SAE J1349)
Max. Torque	202 kgf.m @ 1,500 rpm
Fuel Consumption (Max, Rated)	214 g/kw.hr @ RATED SPEED

The new DOOSAN DX700LC ISUZU engine respects and protects the environment, limiting all types of toxic emissions.

### Cooling System

- The Doosan Cooling Fan Control (DCFC) controls the fan speed. based on coolant temperature and hydraulic oil temperature  
ED REGULATOR VALVE Controls hyd. oil flow inside fan pump
- Audible and visible monitoring sensor  
Water temperature sensor activates water temperature gauge at cluster, overheat prevention system and automatic warming up system.
- Overheat prevention system  
When coolant temperature reaches 110 (230 )  
buzzer and warning lamp at cluster are activated.

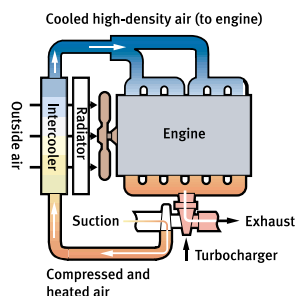
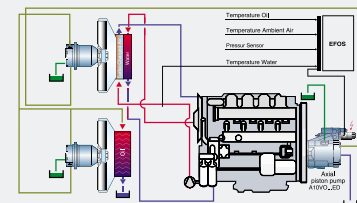

### Valve OHC Turbo Engine with Inter-Cooler

Density of the air increases NOx and PM can be reduced substantially Permitting high output Improvement of fuel efficiency

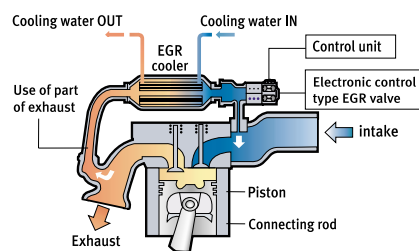

### Cooled EGR System

- EGR (Exhaust Gas Recirculation)
- Lower the combustion temp. reducing NOx(Nitrogen Oxide)

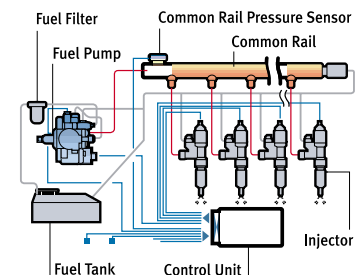

### Common Rail Type High-Pressure Fuel Injection System

High Pressure of more 1600atm 1/1000 second optimizes combustion Improves combustion efficiency & reduce PM (Particulate Matter)

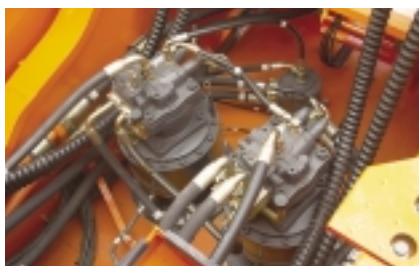

### Swing Motor

- KPM Motor + Sunjin Reduction gear
- Pressure : 260kgf/cm<sup>2</sup>



### Control Valve

- KAYABA : KVMG400
- 320/350 bar, spool Diameter : 35mm



### Hydraulic Pump

- Maker : KPM K3V280DTH
- Max. displacement : 280 cc/rev



# Comfort

The work rate of the hydraulic excavator is directly linked to the performance of its operator. DOOSAN designed the DX 700 LC by putting the operator at the center of the development goals. The result is significant ergonomic value that improves the efficiency and safety of the operator.



## Control panel

More space, better visibility, air conditioning, a very comfortable seat... These are all elements that ensure the operator can work for hours and hours in excellent conditions.

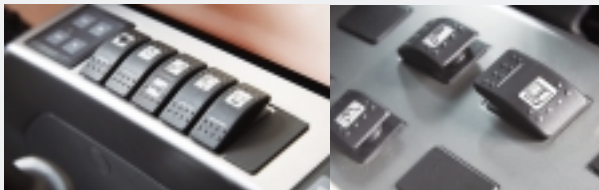





Control stand (Telescopic Function)

Comfortable 2-stage sliding seat



### Control lever

Very precise control of the equipment increases versatility, safety and facilitates tricky operations requiring great precision. Leveling operations and the movement of suspended loads are made easier and safer.



1. Control panel

2. Operation modes

### Choice of operating modes

- Power Mode** - Heavy duty digging & loading
  - Uses 100% Engine power for all work
- STD Mode** - Heavy duty dumping, General, Breaker
  - Flow Distribution Control (Boom, Swing Priority, etc.)
  - Uses 85% Engine power for all work
- E Mode** - Middle duty dumping, digging & loading
  - Uses 75% Engine power for all work
- Lifting Mode** - Pipe or Beam lifting
  - Uses 80% Engine power for all work

### Rear Camera



1. Cellular phone box
2. 24V Power socket
3. Cigarette lighter
4. Glass antenna



# Reliability & Maintenance



The reliability of a product contributes to its overall lifetime operating costs.

Doosan uses computer- assisted design techniques,highly durable materials and a quality engineered structure. Our research and development engineers test all product under the most extreme conditions. Durability,reliability and product longevity are Doosan's top priorities.

## Strengthened Boom

The shape of the boom has been optimized by finite elements design, allowing uniform load distribution throughout the structure.

## Arm Assembly

In the arm assembly greater strength has been gained by using cast elements and reinforcement around the bosses to give increased life.



## Bushing

A highly lubricated metal is used for the boom pivot in order to increase the lifetime and extend the greasing intervals to 250 hours.



## Ultra-hard wear-resistant disc

New materials have been used in order to increase the wear resistance and to increase the service intervals.



## X-chassis

The X-chassis frame section has been designed using finite element and 3-dimensional computer simulation



## Adjustable Truck Frame

- Track Frame Width : with 650 mm shoe
- Work Position : 4,000 mm
- Transport Position : 3400 mm



SHOF

SPRO

Wide Side Step



**Easy maintenance**

Easy access to the various radiators and coolers makes cleaning easier. Access to the various parts of the engine is from the top and via side panels.



**Engine oil filter**

The engine oil filter offers a high level of filtration allowing the oil change interval to be increased to 500 hours.



**Hydraulic oil return filter**

The protection of the hydraulic system is more effective, using glass fiber filter technology in the main oil return filter.



**Air cleaner with Precleaner**

The large capacity forced air cleaner removes over 99% of airborne particles, reducing the risk of engine contamination and making the cleaning and cartridge change intervals greater.

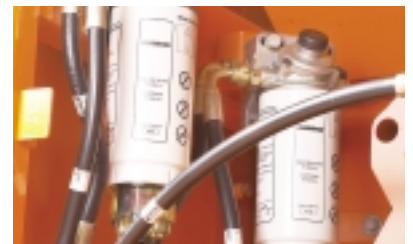

**Double Fuel Pre - Cleaner**

High efficiency fuel filtration is attained by the use of multiple filters, including a fuel pre-filter fitted with a water separator that removes most moisture from the fuel.

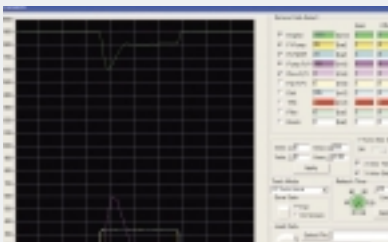

**PC Monitoring (DMS)**

A PC monitoring function enables connection to the e-EPOS system, allowing various parameters to be checked during maintenance



**Convenient Fuse Box**

The fuse box is conveniently located in a section of the storage compartment behind the operator's seat providing a clean environment and easy access.

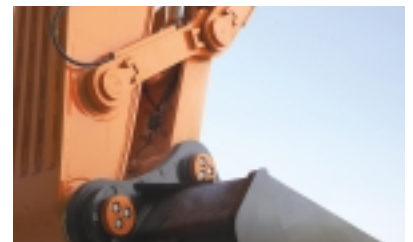

**Auto Greasing System in the all Lubrication Point**

Bucket, Arm, Boom, Swing Bearing & Device are all auto greasing system(STD).

DOOSAN has developed the DX 700 LC profitability with end-user in mined. Easy maintenance operations at long intervals increase the availability of the equipment on site.





Hydraulic Excavator  
DX700LC





*DX700LC*





# Technical Specification

## Engine

### MODEL

ISUZU MOTORS AH-6WG1XYSC-01

### TYPE

Water-Cooled, Common Rail, Direct Injection

### NUMBER OF CYLINDERS

6

### RATED HORSE POWER

345 kW (469 PS) @ 1,800 rpm (DIN 6271)

345 kW (463 HP) @ 1,800 rpm (SAE J1349)

### MAX TORQUE

202kgfm@ 1,500rpm

### PISTON DISPLACEMENT

15,681cc

### BORE & STROKE

Ø147mm X 154mm

### STARTING MOTOR

24 V x 7.0 kW

### BATTERIES

12 V x 2/150 AH

### AIR CLEANER

Double element with precleaner

## Hydraulic System

The heart of the system is the e-EPOS (Electronic Power Optimizing System). It allows the efficiency of the system to be optimized for all working conditions and minimizes fuel consumption. The new e-EPOS is connected to the engine electronic control via a data transfer link to harmonize the operation of the engine and hydraulics.

- The hydraulic system enables independent or combined operations.
- Two travel speeds offer either increased torque or high speed tracking.
- Cross-sensing pump system for fuel savings.
- Auto deceleration system.
- Two operating modes, two power modes.
- Button control of flow in auxiliary equipment circuits.
- Computer-aided pump power control.

### MAIN PUMPS

Tandem, Axial Piston

max flow : 2-436 /min

Displacement - 242 X 2 cc/rev

weight - 300kg

### PILOT PUMP

Gear pump - max flow rate - 27 /min

Displacement : 15 cc/rev

Relief valve pressure - 39.8 kgf/cm<sup>2</sup>

### MAIN RELIEF PRESSURE

Boom/Arm/Bucket

Working, Travel - 320 [+10~0] kg/cm<sup>2</sup>

Pressure up - 350 [+10~0] kg/cm<sup>2</sup>

## Weight

### TRIPLE GROUSER

Shoe width	Operating weight	Ground pressure (kgf/cm <sup>2</sup> )
(STD)650DG mm	70,100 kg	1.02 kgf/cm <sup>2</sup>
(OPT)750DG mm	71,100 kg	0.91 kgf/cm <sup>2</sup>
(OPT)900DG mm	72,100 kg	0.77 kgf/cm <sup>2</sup>

### Hydraulic Cylinders

The piston rods and cylinder bodies are made of high-strength steel. A shock absorbing mechanism is fitted in all cylinders to ensure shock-free operation and extend piston life.

Cylinders	Quantity	Bore x Rod diameter x stroke
Boom	2	Ø190 X Ø125 X 1,795mm
Arm	1(1)	Ø215 X Ø150 X 2030(1890)mm
Bucket	1(1)	Ø190(Ø200) X Ø130 X 1465mm

( ): Opt.

### Undercarriage

Chassis are of very robust construction, all welded structures are designed to limit stresses. High-quality material used for durability. Lateral chassis welded and rigidly attached to the undercarriage. Track rollers lubricated for life, idlers and sprockets fitted with floating seals. Tracks shoes made of induction-hardened alloy with triple grousers. Heat-treated connecting pins. Hydraulic track adjuster with shock-absorbing tension mechanism

**UPPER ROLLERS (STANDARD SHOE)** - 3

**LOWER ROLLERS** - 8

**TRACK SHOES** - 48

**OVERALL LENGTH** - 13,250mm

**TRACK LENGTH** - 5,975mm

### Swing Mechanism

High-torque, axial piston motor with planetary reduction gear bathed in oil. Swing circle is singlerow, shear type ball bearing with induction-hardened internal gear. Internal gear and pinion gear immersed in lubricant.

**TYPE** - Axial Piston

**SWING SPEED** - 7.1 rpm (EFF.=0.98)

**MAX. SWING TORQUE** - 22,070 kgf.m (EFF.=0.77)

### Drive

Each track is driven by an independent, high-torque, axial piston motor through planetary reduction gear. Two levers or foot pedal control provide smooth travel or counter-rotation upon demand.

**TRAVEL SPEED (HIGH / LOW)** - 4.6/2.8km/h (EFF.=97%)

**MAXIMUM TRACTION FORCE** - 48.9/42.4 ton (EFF.=76.4/65.4%)

**GRADEABILITY** - 70%

### Refill Capacities

**FUEL TANK** - 900 (Diesel)

**COOLING SYSTEM (RADIATOR CAPACITY)** - 69 (Water)

**ENGINE OIL** - 52

**SWING DEVICE** - 2x6

**TRAVEL DEVICE** - 2x20

**LEVER** : 350

**OIL TANK** : Lever 350

SYSTEM (TANK FULL) 790



# Dimensions

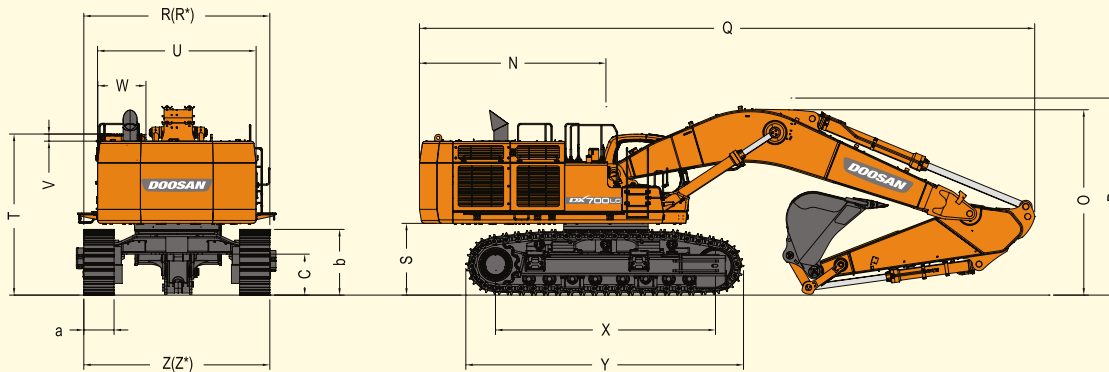

## Standard

Boom type (one piece)	(mm)	7,700			6,650	
Arm length	(mm)	3,550	2,900	4,200	2,900	2,600
Bucket type (SAE)	(m <sup>3</sup> )	3.3	3.3	3.0	3.9	4.5
Tail swing radius	(mm) N	4,090				
Shipping height (boom)	(mm) O	4,063	4,418	5,015	4,920	4,750
Shipping height (hose)	(mm) P	4,220	4,520	5,130	5,000	4,870
Shipping length	(mm) Q	13,250	13,400	13,085	12,335	12,335
Shipping width (std.)	(mm) R	3,410				
Shipping width (narrow)	(mm) R*	-	-	-	-	-
C/Weight clearance	(mm) S	1,525				
Height over cab.	(mm) T	3,515				
House width	(mm) U	3,410				
Cab. Height above House	(mm) V	208				
Cab. width	(mm) W	1,010				
Tumbler distance	(mm) X	4,730				
Track length	(mm) Y	5,975				
Undercarriage width (std.)	(mm) Z	3,400/4,000*				
Undercarriage width (narrow)	(mm) Z'	-	-	-	-	-
Shoe width	(mm) a	650				
Track height	(mm) b	1,413				
Car body clearance	(mm) c	870				

[Note] \*: Retracted / Extended

# Working Range

DX700LC

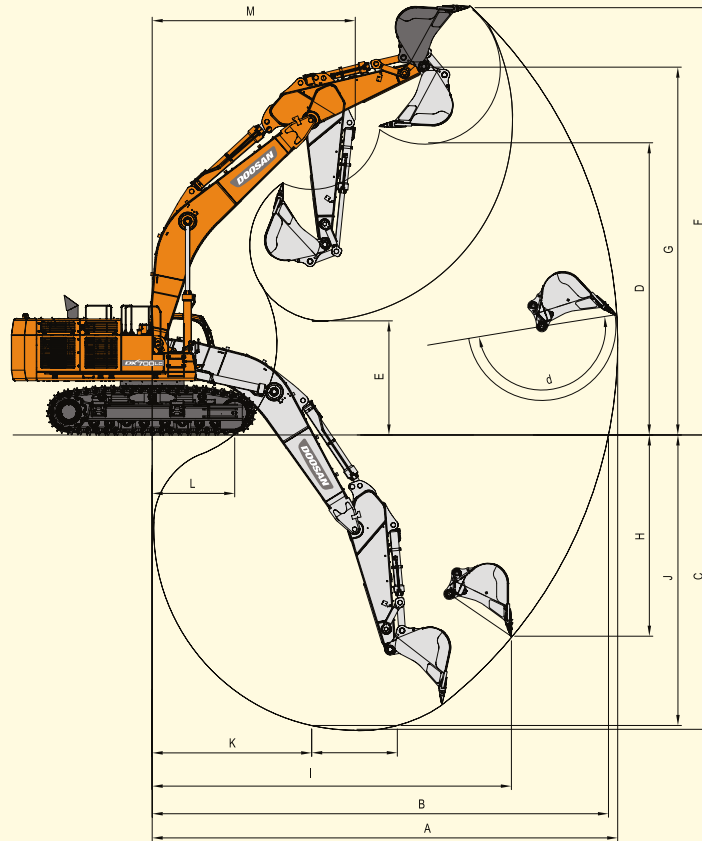

Boom type (one piece)	(mm)	7,700			6,650	
Arm length	(mm)	3,550	2,900	4,200	2,900	2,600
Bucket type (SAE)	(m <sup>3</sup> )	3-3		3.0	3.9	4.5
Max. Digging reach	(mm) A	13,250	12,720	13,865	11,605	11,345
Max. Digging reach (ground)	(mm) B	12,990	12,450	13,610	11,305	11,040
MAX. Digging depth	(mm) C	8,410	7,730	9,030	7,075	6,780
Max. dumping height	(mm) D	8,320	8,220	8,660	7,020	6,940
Min. dumping height	(mm) E	3,248	3,950	2,630	3,080	3,380
Max. digging height	(mm) F	12,165	12,040	12,520	10,740	10,680
Max. bucket pin height	(mm) G	10,470	10,380	10,795	9,210	9,135
Max. vertical wall depth	(mm) H	5,730	4,060	6,515	3,450	3,305
Max. radius vertical	(mm) I	10,230	10,790	10,360	9,860	9,655
Max. depth to 8' line	(mm) J	8,270	7,550	8,910	6,925	6,620
Min. radius 8' line	(mm) K	4,540	4,530	10,360	3,800	3,785
Min. digging reach	(mm) L	2,350	3,060	170	1,835	2,050
Min. swing radius	(mm) M	5,780	5,790	5,810	5,230	5,195
Bucket angle	(deg) d	179.4	177.8	179.4	167.4	166.4



# Lifting Capacity

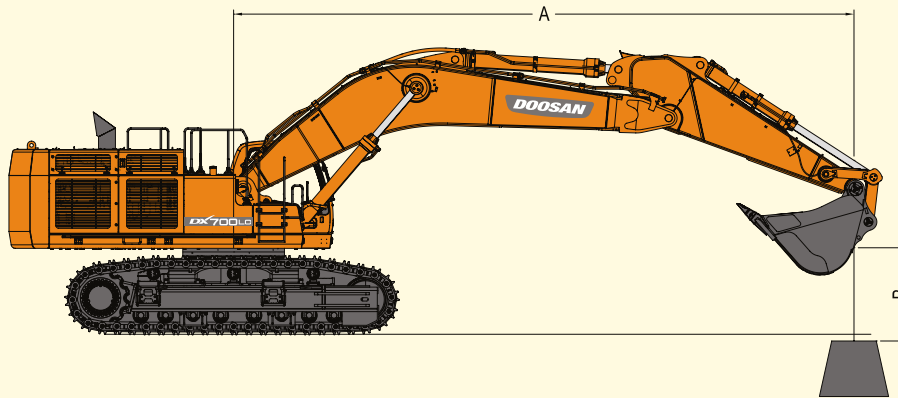

## Standard

Boom : 7,700mm(25'3") Arm : 3,550m(11'3") Bucket : SAE 3.3m<sup>3</sup> Shoe : 650mm(2'2") GP Bucket 11300kg C/W

### Metric

Unit : 1,000kg

B(m)	3		4-5		6		7-5		9		10.5		Max. Reach		A(ft)
30									* 9.36	* 9.36			* 8.38	* 8.38	9.15
25									* 11.44	* 11.44			* 8.23	* 8.23	9.78
20							* 13.62	* 13.62	* 12.03	11.75	* 9.72	8.61	* 8.34	8.34	10.28
15			* 26.60	* 26.60	* 18.99	* 18.99	* 15.16	* 15.16	* 12.88	11.2	* 11.41	8.34	* 8.71	7.53	10.65
10					* 21.70	20.62	* 16.70	14.44	* 13.76	10.63	* 11.85	8.02	* 9.34	7.09	10.93
5					* 23.51	19.3	* 17.89	13.62	* 14.47	10.12	12.15	7.73	* 10.31	6.94	11.10
0			* 28.31	* 28.31	* 24.09	18.59	* 18.47	13.07	* 14.81	9.76	11.94	7.53	11.27	7.09	10.87
-5	* 24.16	* 24.16	* 31.28	30.2	* 23.53	18.35	* 18.27	12.82	* 14.58	9.58			* 11.81	7.61	10.58
-10	* 32.85	* 32.85	* 28.23	* 28.23	* 21.85	18.45	* 17.14	12.83	* 13.46	9.63			* 11.93	8.65	10.18
-15	* 30.06	* 30.06	* 23.82	* 23.82	* 18.80	* 18.80	* 14.66	13.14					* 11.76	10.7	9.66
-20			* 17.10	* 17.10	* 13.53	* 13.53							* 10.71	* 10.71	8.99

### Feet

Unit : 1,000lb

B(ft)	10		15		20		25		30		35		Max. Reach		A(ft)
30													* 18.55	* 18.55	29.66
25									* 25.02	* 25.02			* 18.14	* 18.14	32.75
20							* 29.50	* 29.50	* 26.17	25.2			* 18.36	* 18.36	34.85
15			* 56.84	* 56.84	* 40.86	False	* 32.76	* 32.76	* 27.93	24.05	* 24.84	17.83	* 19.15	16.67	36.13
10					* 46.74	44.45	* 36.07	31.08	* 29.80	22.82	* 25.71	17.18	* 20.53	15.64	36.68
5					* 50.76	41.55	* 38.67	29.3	* 31.32	21.74	26.08	16.57	* 22.69	15.3	36.53
0			* 64.51	* 64.51	* 52.13	39.96	* 39.94	28.11	* 32.03	20.96	25.64	16.16	* 24.85	15.64	35.68
-5	* 54.04	* 54.04	* 67.72	64.66	* 50.96	39.4	* 39.50	27.55	* 31.45	20.59			* 26.03	16.79	34.07
-10	* 73.64	* 73.64	* 61.22	* 61.22	* 47.25	39.63	* 36.95	27.59	* 28.82	20.72			* 26.30	19.19	31.58
-15	* 64.94	* 64.94	* 51.36	* 51.36	* 40.40	* 40.40	* 31.25	28.32					* 25.89	23.89	27.98
-20			* 36.15	* 36.15	* 28.29	* 28.29							* 23.32	* 23.32	22.71

1. RATINGS ARE BASED ON SAE J1097
2. THE LOAD POINT IS A HOOK LOCATED ON THE BACK OF THE BUCKET.
3. \* RATED LOADS ARE BASED ON HYDRAULIC CAPACITY.
4. RATED LOADS DO NOT EXCEED 87% OF HYD. CAPACITY OR 75% OF TIPPING CAPACITY.

: Rating Over Front

: Rating Over Side or 360 degree

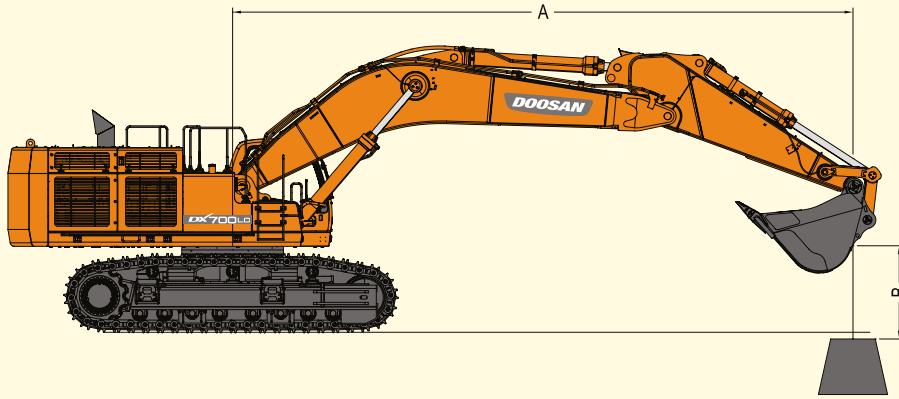

Opton 1

Boom : 7,700mm(25'3") Arm : 2,900m(9'6") Bucket : SAE 3.3m³ Shoe : 650mm(2'2") GP Bucket 11300kg C/W

Metric

Unit : 1,000kg

B(m)	3		4-5		6		7-5		9		10.5		Max. Reach		A(ft)
	Front	Side	Front	Side	Front	Side	Front	Side	Front	Side	Front	Side	Front	Side	
9													* 10.66	* 10.66	8.60
7-5									* 11.92	11.71			* 10.46	10.31	9.55
6							* 14.17	* 14.17	* 12.40	10.82			* 10.62	8.78	10.19
4-5					* 19.77	* 19.77	* 15.59	14.93	* 13.14	10.82	* 11.59	8	* 11.10	7.87	10.58
3					* 22.17	19.81	* 16.95	13.95	* 13.90	10.27	* 11.90	7.73	* 11.63	7.39	10.74
1-5					* 23.52	18.63	* 17.91	13.18	* 14.45	9.81	11.91	7.49	11.55	7.25	10.69
0					* 23.62	18.09	* 18.21	12.72	* 14.59	9.5			11.91	7.45	10.42
-1.5			* 29.07	* 29.07	* 22.62	18.01	* 17.71	12.56	* 14.08	9.4			* 12.10	8.07	9.92
-3	* 30.81	* 30.81	* 25.80	* 25.80	* 20.52	18.26	* 16.19	12.69	* 12.45	9.57			* 12.07	9.36	9.14
-4-5	* 24.55	* 24.55	* 20.93	* 20.93	* 16.92	* 16.92	* 13.03	* 13.03					* 11.58	* 11.58	8.00
-6					* 10.46	* 10.46							* 9.59	* 9.59	6.32

Feet

Unit : 1,000lb

B(ft)	10		15		20		25		30		35		Max. Reach		A(ft)
	Front	Side	Front	Side	Front	Side	Front	Side	Front	Side	Front	Side	Front	Side	
30													* 23.59	* 23.59	27.85
25									* 26.09	25.01			* 23.06	* 23.06	31.12
20							* 30.68	* 30.68	* 26.97	24.32			* 23.37	19.52	33.33
15					* 42.54	* 42.54	* 33.68	32.13	* 28.49	23.23			* 24.41	17.43	34.67
10					* 47.78	42.72	* 36.62	30.03	* 30.09	22.06	* 25.80	16.54	* 25.63	16.31	35.24
5					* 50.81	40.11	* 38.72	28.37	* 31.26	21.06	25.56	16.05	25.45	15.97	35.09
0			* 60.08	* 60.08	* 51.15	38.89	* 39.39	27.35	* 31.52	20.41			26.25	16.42	34.20
-5			* 63.27	* 63.27	* 49.02	38.68	* 38.28	27	* 30.32	20.21			* 26.68	17.83	32.51
-10	* 67.35	* 67.35	* 56.01	* 56.01	* 44.38	39.22	* 34.85	27.3					* 26.60	20.76	29.89
-15	* 53.05	* 53.05	* 45.10	* 45.10	* 36.27	* 36.27	* 27.51	* 27.51					* 25.43	* 25.43	26.06
-20					* 21.17	* 21.17							* 20.57	* 20.57	20.28

1. RATINGS ARE BASED ON SAE J1097
2. THE LOAD POINT IS A HOOK LOCATED ON THE BACK OF THE BUCKET.
3. \* RATED LOADS ARE BASED ON HYDRAULIC CAPACITY.
4. RATED LOADS DO NOT EXCEED 87% OF HYD. CAPACITY OR 75% OF TIPPING CAPACITY.

: Rating Over Front  
 : Rating Over Side or 360 degree



# Lifting Capacity

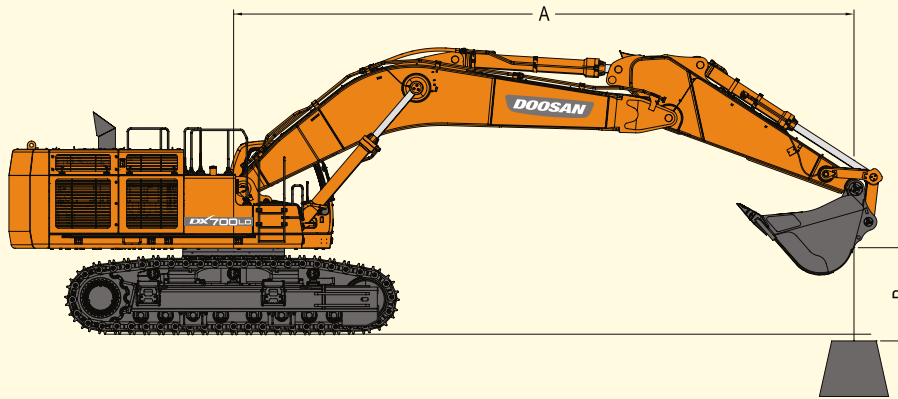

## Option 2

Boom : 7,700mm(25'3") Arm : 4,200mm(13'9") Bucket : SAE 3.0m<sup>3</sup> Shoe : 650mm(2'2") GP Bucket 11300kg C/W

### Metric

Unit : 1,000kg

A(m) B(m)	1.5		3		4.5		6		7.5		9		10.5		Max. Reach		A(ft)				
9															* 6.67	* 6.67	9.94				
7.5												* 10.55	* 10.55	* 8.17	* 8.17	* 6.51	* 6.51	10.78			
6												* 11.23	* 11.23	* 10.34	8.82	* 6.56	* 6.56	11.35			
4.5							* 17.51	* 17.51	* 14.19	* 14.19	* 12.16	11.42	* 10.83	8.49	* 6.79	6.74	11.70				
3							* 20.48	* 20.48	* 15.89	14.75	* 13.17	10.8	* 11.38	8.12	* 7.21	6.35	11.84				
1.5							* 22.74	19.71	* 17.32	13.83	* 14.04	10.23	* 11.86	7.78	* 7.87	6.21	11.80				
0							* 28.81	* 28.81	* 23.88	18.77	* 18.20	13.17	* 14.60	9.79	11.91	7.51	* 8.85	6.32	11.56		
-1.5							* 22.52	* 22.52	* 32.47	30.04	* 23.85	18.33	* 18.35	12.79	* 14.65	9.52	11.76	7.37	* 10.36	6.71	11.10
-3	* 24.86	* 24.86	* 29.49	* 29.49	* 32.47	* 30.12	* 30.12	* 22.70	18.28	* 17.65	12.69	* 13.99	9.46			* 11.02	7.51	10.41			
-4.5	* 31.53	* 31.53	* 35.41	* 35.41	* 26.36	* 26.36	* 20.30	18.54	* 15.83	12.86	* 12.13	9.66			* 11.02	9	9.43				
-6			* 26.54	* 26.54	* 20.65	* 20.65	* 16.11	* 16.11	* 12.12	* 12.12					* 10.52	* 10.52	8.07				

### Feet

Unit : 1,000ld

A(ft) B(ft)	5		10		15		20		25		30		35		Max. Reach		A(ft)	
30																* 14.77	* 14.77	32.32
25																* 23.04	* 23.04	35.17
20																* 24.41	* 24.41	37.13
15																* 26.38	24.52	38.33
10																* 30.67	* 30.67	38.85
5																* 44.11	* 44.11	38.85
0																* 64.97	* 64.97	38.71
-5																* 65.64	64.94	37.91
-10																* 50.37	* 50.37	36.40
-15	* 55.33	* 55.33	* 66.09	* 66.09	* 65.24	64.77	* 49.09	39.25	* 38.10	27.27	* 30.07	20.34			* 24.31	16.64	34.08	
-20																* 70.41	* 70.41	30.77
																* 56.53	* 56.53	26.10

1. RATINGS ARE BASED ON SAE J1097

2. THE LOAD POINT IS A HOOK LOCATED ON THE BACK OF THE BUCKET.

3. \* RATED LOADS ARE BASED ON HYDRAULIC CAPACITY.

4. RATED LOADS DO NOT EXCEED 87% OF HYD. CAPACITY OR 75% OF TIPPING CAPACITY.

: Rating Over Front

: Rating Over Side or 360 degree

### Opton 3

Boom : 6,650mm(21'10") Arm : 2,900mm(9'6") Bucket : SAE 3.9m<sup>3</sup> Shoe : 650mm(2'2") GP Bucket 11300kg C/W

#### Metric

Unit : 1,000kg

A(m) B(m)	3		4.5		6		7.5		9		Max. Reach		A(ft)
7.5							* 14.24	* 14.24			* 10.04	* 10.04	8.26
6							* 15.02	* 15.02			* 10.17	* 10.17	8.99
4.5			* 26.17	* 26.17	* 19.72	* 19.72	* 16.34	15.98	* 14.34	11.49	* 10.70	10.49	9.43
3					* 22.46	21.83	* 17.79	15.14	* 15.02	11.06	* 11.65	9.8	9.61
1.5			* 34.63	32.73	* 24.45	20.54	* 18.94	14.41	* 15.53	10.67	* 13.18	9.62	9.56
0			* 34.68	31.87	* 25.16	19.78	* 19.40	13.92	* 15.52	10.41	* 14.93	9.95	9.26
-1.5	* 36.17	* 36.17	* 32.71	31.81	* 24.40	19.52	* 18.81	13.72			* 15.34	10.96	8.68
-3	* 38.29	* 38.29	* 28.79	* 28.79	* 21.90	19.7	* 16.53	13.89			* 15.56	13.17	7.78
-4.5	* 28.12	* 28.12	* 22.07	* 22.07	* 16.56	* 16.56					* 15.02	* 15.02	6.40

#### Feet

Unit : 1,000d

A(ft) B(ft)	10		15		20		25		30		Max. Reach		A(ft)
25							* 31.14	* 31.14			* 22.15	* 22.15	26.86
20							* 32.69	* 32.69			* 22.38	* 22.38	29.38
15			* 56.11	* 56.11	* 42.57	* 42.57	* 35.44	34.35	* 30.73	24.61	* 23.50	23.23	30.89
10			* 68.17	* 68.17	* 48.48	47	* 38.54	32.56	* 32.61	23.73	* 25.60	21.64	31.54
5			* 74.82	70.31	* 52.86	44.19	* 41.01	30.99	* 33.65	22.9	* 29.00	12.12	31.37
0			* 75.19	68.33	* 54.46	42.52	* 41.98	29.92	* 33.50	22.37	* 32.93	12.93	30.37
-5	* 81.07	* 81.07	* 70.95	68.14	* 52.81	41.94	* 40.61	29.52			* 33.82	24.2	28.45
-10	* 83.06	* 83.06	* 62.26	* 62.26	* 47.20	42.35	* 35.27	29.93			* 34.29	29.23	25.41
-15	* 60.21	* 60.21	* 47.12	* 47.12	* 34.88	* 34.88					* 32.97	* 32.97	20.73

### Opton 4

Boom : 6,650mm(21'10") Arm : 2,600mm(8'6") Bucket : SAE 4.5m<sup>3</sup> Shoe : 650mm(2'2") GP Bucket 11300kg C/W

#### Metric

Unit : 1,000kg

A(m) B(m)	3		4.5		6		7.5		9		Max. Reach		A(ft)
7.5							* 14.67	* 14.67			* 11.13	* 11.13	7.98
6							* 15.38	* 15.38			* 11.31	* 11.31	8.73
4.5			* 27.23	* 27.23	* 20.23	* 20.23	* 16.64	15.74	* 14.53	11.27	* 11.95	10.83	9.18
3					* 22.83	21.51	* 18.00	14.93	* 15.12	10.89	* 13.08	10.1	9.37
1.5					* 24.60	20.29	* 19.02	14.24	* 15.52	10.53	* 14.91	9.93	9.31
0			* 34.20	31.67	* 25.03	19.62	* 19.30	13.8	* 15.31	10.32	* 15.30	10.31	9.00
-1.5	* 37.60	* 37.60	* 31.83	31.76	* 23.98	19.45	* 18.46	13.67			* 15.65	11.46	8.41
-3	* 35.52	* 35.52	* 27.52	* 27.52	* 21.09	19.72					* 15.74	14	7.48
-4.5	* 24.91	* 24.91	* 20.18	* 20.18	* 14.91	* 14.91					* 14.78	* 14.78	6.03

#### Feet

Unit : 1,000d

A(ft) B(ft)	10		15		20		25		30		Max. Reach		A(ft)
25							* 30.35	* 30.35			* 24.55	* 24.55	25.91
20							* 33.47	* 33.47			* 24.89	* 24.89	28.53
15			* 58.36	* 58.36	* 43.66	* 43.66	* 36.08	33.82	* 27.11	24.12	* 26.24	23.99	30.08
10					* 49.28	46.33	* 38.97	32.11	* 32.82	23.34	* 28.73	22.3	30.74
5			* 75.09	69.37	* 53.18	43.66	* 41.16	30.62	* 33.58	22.61	* 32.79	21.88	30.57
0			* 74.21	67.89	* 54.19	42.18	* 41.75	29.62			* 33.72	22.74	29.54
-5	* 84.30	* 84.30	* 69.08	68.03	* 51.89	41.8	* 39.80	29.4			* 34.50	25.31	27.57
-10	* 77.11	* 77.11	* 59.52	59.52	* 45.40	42.41					* 34.68	31.14	24.41
-15			* 42.93	* 42.93							* 32.33	* 32.33	19.49

1. RATINGS ARE BASED ON SAE J1097
2. THE LOAD POINT IS A HOOK LOCATED ON THE BACK OF THE BUCKET.
3. \* RATED LOADS ARE BASED ON HYDRAULIC CAPACITY.
4. RATED LOADS DO NOT EXCEED 87% OF HYD. CAPACITY OR 75% OF TIPPING CAPACITY.

: Rating Over Front  
 : Rating Over Side or 360 degree



## Официальный представитель

ООО «Технопарк»

664058, г.Иркутск, ул. Сергеева, д.3, к.2, оф.10

Тел.: (3952) 722-797, 722-878,

Факс: (3952) 56-36-95,

[www.techno-park.com](http://www.techno-park.com),

e-mail: [info@techno-park.com](mailto:info@techno-park.com)



[www.doosaninfracore.com](http://www.doosaninfracore.com)

The illustrations do not necessary show the product in standard version. All products and equipment are not available in all markets. Materials and specifications are subject to change without prior notice.